



# **Treatment wetlands in the UK: Case studies of an established biological treatment technology**

**Prepared by:**

**Gabriela Dotro, PhD, FHEA**

**Chair, Constructed Wetland Association**

**NbS Future**

**and**

**John Williams, PhD, MCIWEM, CWEM, CEnv, FHEA**

**CWA committee member**

**Professor of Environmental Technology,**

**University of Portsmouth**

*Version 2. Issued March 2025*

## Table of Contents

Executive Summary.....	4
Treatment wetlands in the UK: Case studies of an established biological treatment technology	5
1. Introduction .....	5
1.1 Microbial activity in treatment wetlands.....	5
1.2 Methodology.....	6
1.3 Treatment wetland classification .....	7
2. Treatment wetlands in the UK.....	7
2.1. General overview of wetlands in the UK.....	12
2.2 Secondary treatment.....	12
2.3 Stepped high flows applications for secondary and tertiary treatment .....	18
3 Pathogen removal.....	22
4 International experience .....	24
5 Discussion .....	26
6 Conclusions.....	27
Appendix A. Overview of treatment wetland terminology .....	28
Appendix B. Summary of case studies for storm overflow applications.....	29
References .....	40
About the authors .....	42



## Foreword

---

The Constructed Wetland Association (CWA), established in 2000, brings together professionals from academia, design firms, and water utilities including Severn Trent, Anglian Water, and Wessex Water. Our mission is to promote constructed wetland technology for water pollution control and advocate for its application in delivering multiple environmental benefits.

In November 2024, Stantec approached the CWA requesting evidence on treatment wetlands in the UK as established biological treatment systems. This information was needed to inform their discussions with the Environment Agency. In line with our commitment to support and inform wetland implementation, our Management Committee appointed Dr. Gabriela Dotro and Professor John Williams to compile this evidence and provide expert feedback on the technology description.

This report presents our findings and demonstrates the effectiveness of treatment wetlands as a proven biological treatment solution. It is intended for water industry professionals, regulatory authorities, and environmental consultants seeking evidence-based information on treatment wetland performance in the UK. Detailed biographies of the authors can be found at the end of this document.

This March 2025 document is a revised version of our original report issued in January 2025, incorporating additional data and case studies.

On behalf of the Constructed Wetland Association

Gabriela Dotro, Chair  
Andy Freeman, Treasurer  
Lucy Crockford, Secretary  
Sarah Belton, Member  
Izzy Love, Member  
Dan Roberts, Member  
Matthew Simpson, Member  
John Williams, Member

March 2025

## Executive Summary

The Constructed Wetland Association (CWA) was approached on 21st November 2024 by Stantec to provide evidence on the use of treatment wetlands in the UK for biological treatment. This report presents comprehensive evidence of treatment wetlands as an established biological treatment technology with 40 years of successful implementation in the UK water industry.

### Methodology

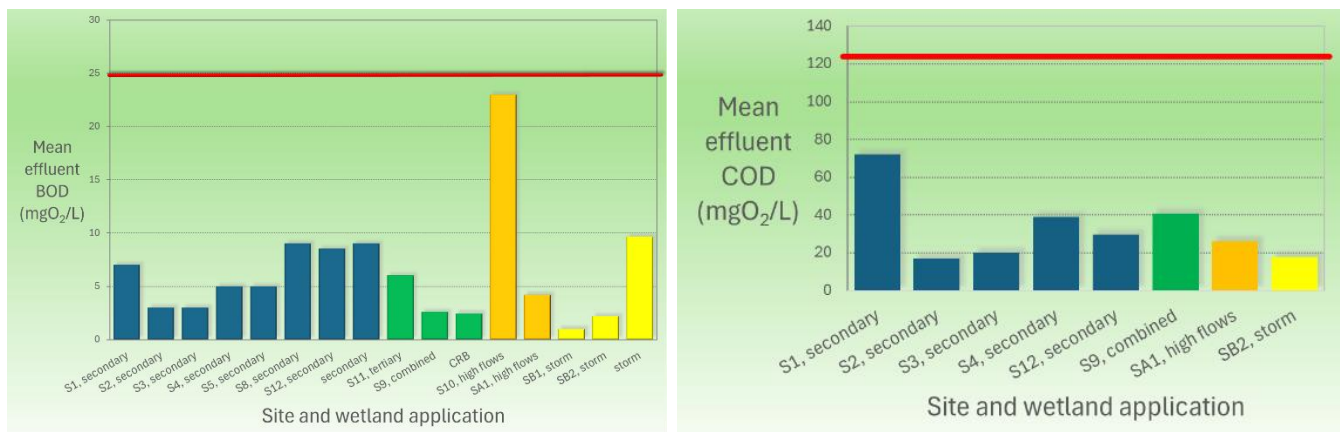
The evidence presented combines published literature (peer-reviewed papers, conference proceedings, research theses), Environment Agency compliance data, water utility sampling programs, and site-specific information from water companies and specialised consultancies.

The data was analysed in the context of current state-of-the-art literature, design guidelines, and European experience reported in scientific publications.

This report summarises 17 detailed case studies covering various applications, with additional aggregated data from 19 secondary treatment wetlands and 52 combined/stepped high flows treatment wetlands from publications.

### Key findings

- ✓ **Established technology:** Treatment wetlands have been used by the UK water industry since 1985, with the UK pioneering gravel-based subsurface flow wetlands in the early 1990s.
- ✓ **Diverse applications:** Treatment wetlands have been successfully implemented across multiple configurations for primary, secondary, tertiary, combined tertiary and stepped high flows, and storm overflow treatment.
- ✓ **Scale versatility:** Evidence from case studies shows effective treatment across all scales, from small rural works to systems serving 7,600+ people.
- ✓ **Configuration flexibility:** UK experience includes successful implementation of horizontal flow, vertical flow, surface flow, and French wetland systems.
- ✓ **Performance data:** Analysis of multiple sites demonstrates consistent compliance with Urban Wastewater Treatment Regulations. Performance data shows average 87% removal efficiency for BOD (n=11 sites), and average 80% removal efficiency for COD (n=7 sites).



**Figure 1.** Performance of treatment wetlands across various applications showing mean and 95%ile effluent concentrations in relation to UWWTR requirements.

# Treatment wetlands in the UK: Case studies of an established biological treatment technology

## 1. Introduction

---

The use of engineered wetlands for wastewater treatment emerged in Germany in the 1950s and 1960s through the work of Seidel and Kickuth (Vymazal 2011). Kickuth pioneered the Root Zone Method where reeds grew in a soil substrate and wastewater passed horizontally through the system, whereas Seidel's design were what are now vertical flow wetlands. The technology spread across Europe in the 1980s and 1990s. Modifications of the technology were known by a variety of names (e.g. artificial wetlands, gravel bed hydroponics, reed beds, etc) until Constructed Wetlands became the generally accepted name in the early 1990s.

Through international conferences and publications, constructed wetlands gained worldwide recognition as a cost-effective alternative to conventional "grey" infrastructure. In 2009, terminology shifted to "treatment wetlands" to distinguish them from wetlands built for other purposes (e.g., habitat creation, mitigation). Today, treatment wetlands are a mainstream technology with thousands of installations worldwide treating diverse wastewaters.

There are many configurations of treatment wetlands. These were summarised in the Treatment Wetlands book issued by the International Water Association as part of their Biological Wastewater Treatment Series (Dotro et al 2017), and a very brief overview is offered in [section 1.3](#) of this report and [Appendix A](#).

### 1.1 Microbial activity in treatment wetlands

Treatment wetlands provide a variety of treatment processes including physical filtration and/or settling, microbial breakdown of pollutants, microbial nutrient cycling and a variety of mechanisms of pathogen inactivation.

The role of microbial activity in treatment wetlands has been recognised since the early days, with the Root Zone Method name referring to the role of many wetland plants in creating oxidised conditions in their rhizospheres to promote aerobic microbial treatment mechanism in reduced/anoxic wetland environments. Treatment wetlands therefore provide very heterogeneous environments for microbial activity with biofilms on substrates and plant surfaces interacting with microorganisms and chemical conditions in the bulk water. The importance of these environments in close proximity to each other has been recognised and studied for over 30 years with microbial activity assays, microelectrodes and more recently metagenomic studies of wetland microbial populations. The influence of these microbial processes is clearly seen in the removals of soluble pollutants, as well as particulates, seen in many treatment wetland case studies. This includes evidence of complex microbial communities able to provide biological treatment of the pollutants in combined sewer overflows (CSOs; Ruppelt et al., 2020). A review of microbial communities found in different types of biological treatment processes ranging from activated sludge to treatment wetlands summarised the diversity of microorganisms that operate in this established technology (Ferrera and Sanchez 2016).

Treatment wetlands for secondary treatment are common in Europe and considered as conventional as grey technologies. To illustrate, in Austria, secondary vertical flow (VF) wetlands are an established treatment alternative to sequencing batch reactors, activated sludge, trickling filters and rotating biological contactors (Engstler et al 2022). Austrian wetlands need to reduce ammonia even in small works, with a cold temperature clause being activated at 12°C. A recent study compared performance across the various secondary treatment technologies, showing the ability of wetlands to match or provide better quality effluent than grey technologies (Engstler et al 2022). The thresholds for compliance applied to the datasets between 2009-2018 were 25 mg/L for BOD and 90 mg/L for COD, the latter being lower than Urban Wastewater Treatment Regulations (UWWTR) that apply to sites serving over 2,000 pe (Table 1.1).

**Table 1.1 Performance of different biological treatment technologies for BOD and COD at small WWTP (reproduced from Engstler et al 2022)**

**TABLE 2 |** BOD<sub>5</sub> effluent concentrations of small WWTPs with different technologies (threshold: 25 mg BOD<sub>5</sub>/L).

BOD <sub>5</sub>	SBR	SBR & VF bed	CAS	CAS & VF bed	VF wetland	Trickling filter	RBC	MBR	Filtration	All data
Number of WWTPs [ ]	493	252	540	52	491	85	36	25	7	1'981
Number of values [ ]	3'358	1'563	4'402	422	3'235	700	279	185	54	14'198
Values above threshold [ ]	5	3	5	3	3	8	7	4	6	5
[%]	0.1	0.2	0.1	0.7	0.1	1.1	2.5	2.2	11.1	0.0
<b>Median [mg/L]</b>	<b>7</b>	<b>5</b>	<b>7</b>	<b>5</b>	<b>5</b>	<b>9</b>	<b>9</b>	<b>5</b>	<b>8</b>	<b>6</b>
Mean [mg/L]	7	3	8	4	3	6	7	5	5	7
Standard deviation [mg/L]	55	10	72	19	10	35	44	20	27	44

*Bold values indicate the median values.*

**TABLE 3 |** COD effluent concentrations of small WWTPs with different technologies (threshold: 90 mg COD/L).

COD	SBR	SBR & VF bed	CAS	CAS & VF bed	VF wetland	Trickling filter	RBC	MBR	Filtration	All data
Number of small WWTPs [ ]	493	252	540	52	491	85	36	25	7	1'981
Number of values [ ]	3'365	1'568	4'406	422	3'245	703	283	185	54	14'231
Values above threshold [ ]	48	7	53	1	4	11	4	0	0	128
[%]	1.4	0.4	1.2	0.2	0.1	1.6	1.4	0.0	0.0	0.9
<b>Median [mg/L]</b>	<b>37</b>	<b>24</b>	<b>35</b>	<b>24</b>	<b>21</b>	<b>44</b>	<b>43</b>	<b>27</b>	<b>33</b>	<b>31</b>
Mean [mg/L]	42	28	41	40	25	47	47	31	34	36
Standard deviation [mg/L]	25	16	38	249	14	22	21	15	14	51

*Bold values indicate the median values.*

SBR = sequencing batch reactor, VF = vertical flow wetland, CAS = conventional activated sludge, RBC = rotating biological contactor, MBR = membrane bioreactor.

## 1.2 Methodology

Published literature including peer-reviewed papers, conference proceedings, and research thesis were searched online to collate information about water utility sites performance in the UK. In addition, end users and designers were contacted to obtain site names of various schemes that were either in the public domain or known to the CWA. Once site names were obtained, the Environment Agency's (EA; Defra 2025) compliance database was queried, and sample records were downloaded for each of the sites according to their date of establishment and/or upgrades. Where water utilities had additional data (e.g., crude or inlet to wetlands) as

part of their investigations, this was obtained and added to the datasets. Finally, information was also gathered from specialist consultancy websites but used solely for reference.

The data was placed in context of current state-of-the-art literature, including textbooks, design guidelines and experience with the technology in Europe as reported in scientific publications.

### 1.3 Treatment wetland classification

Treatment wetlands can be classified according to their water table position and flow direction. The main types used in wastewater treatment applications include:

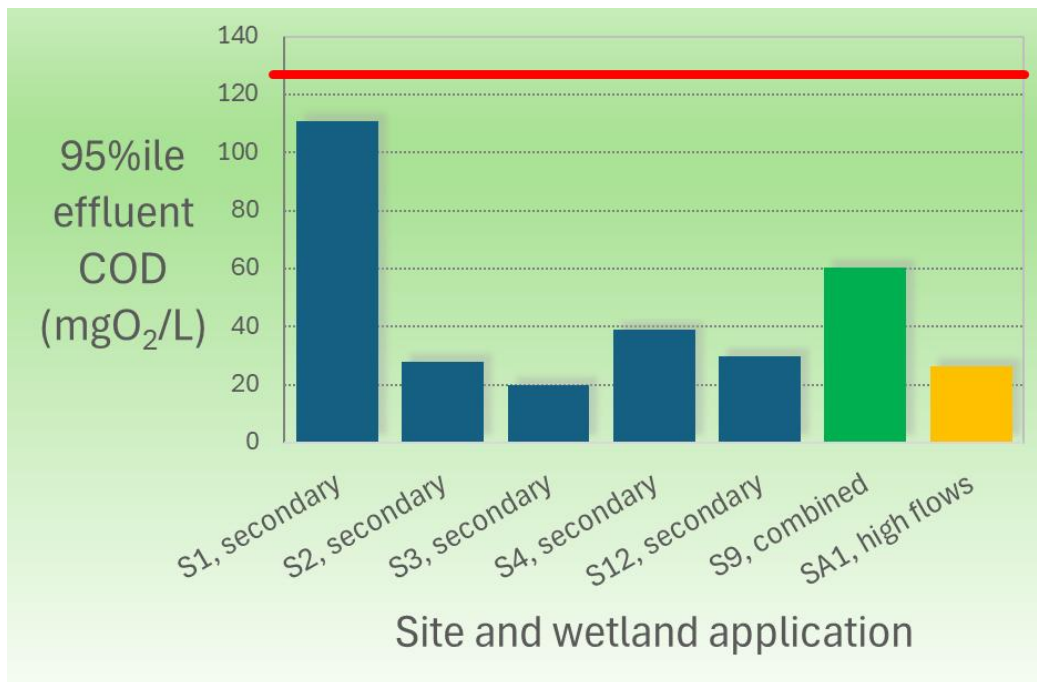
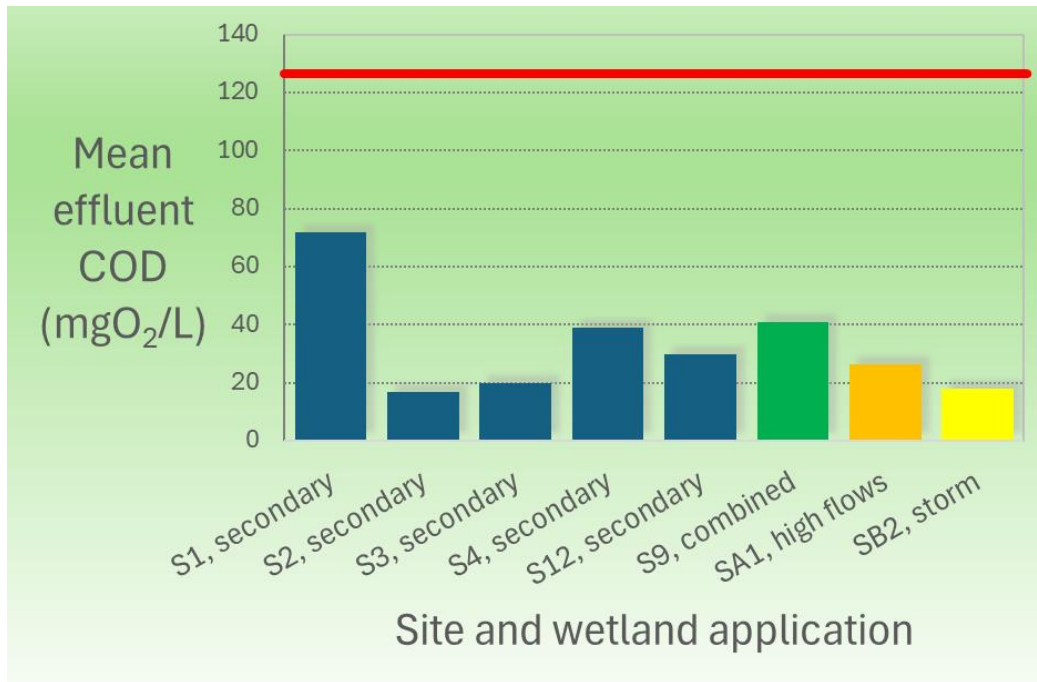
1. **Horizontal Flow (HF):** Wastewater flows horizontally through a porous (typically gravel) substrate planted with emergent vegetation, primarily under anoxic/anaerobic conditions with limited oxygen transfer.
2. **Vertical Flow (VF):** Wastewater is distributed across the surface, fed in predetermined batches, and allowed to drain through different layers of porous substrate (main treatment media is sand), providing aerobic conditions.
3. **Surface Flow (SF):** Also known as Free Water Surface wetlands or Integrated Constructed Wetlands (ICWs), these systems have water flowing above the substrate with emergent vegetation, resembling natural marshes.
4. **French VF Wetlands:** A specialised two-stage VF system treating raw wastewater, with the first stage providing both solids separation and treatment.
5. **Aerated Wetlands** - Artificially aerated versions of HF or VF wetlands, incorporating coarse bubble aeration to enhance oxygen transfer and treatment capacity.

These basic classifications have been further developed into various hybrid systems and specialised configurations for specific treatment objectives. The detailed classification and profile schematics are provided in [Appendix A](#).

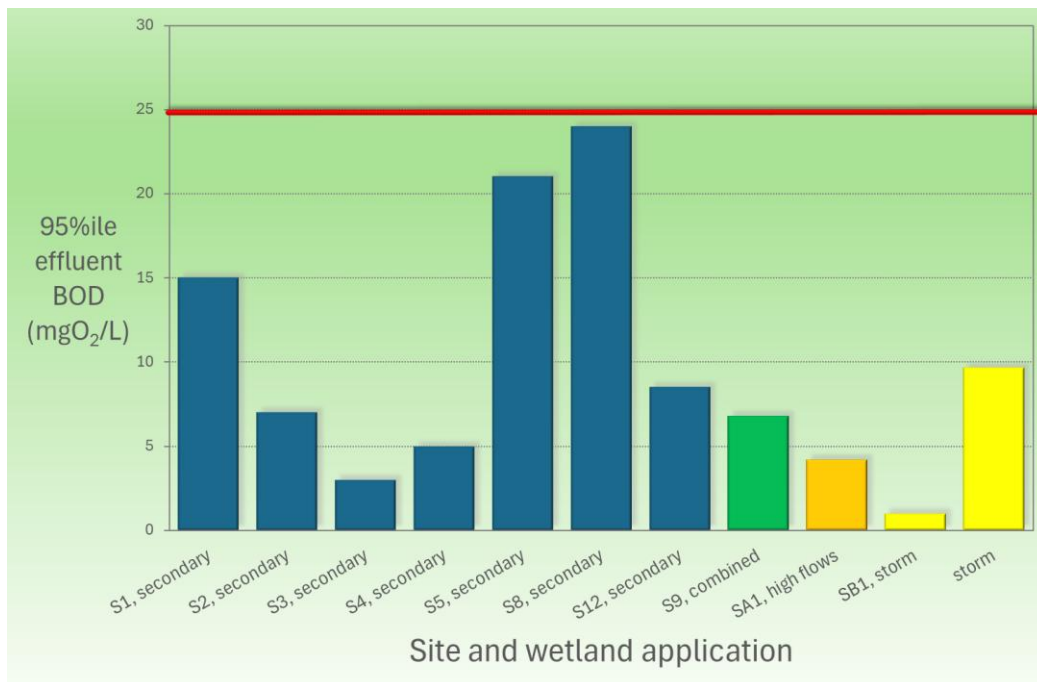
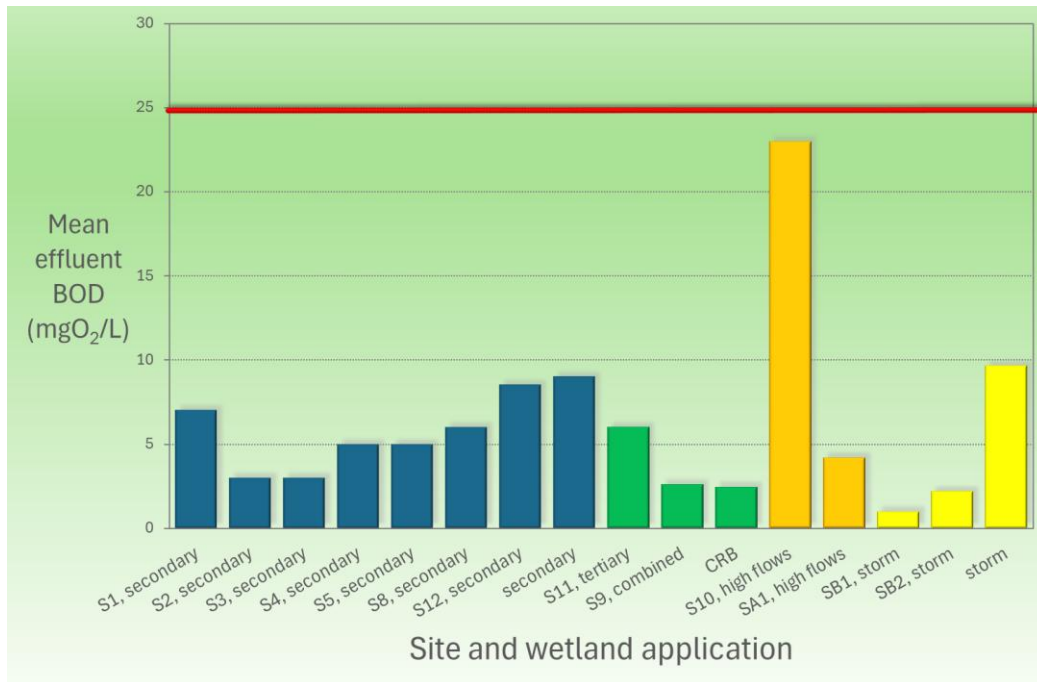
## 2. Treatment wetlands in the UK

---

This section examines the evolution and implementation of treatment wetlands across the UK, beginning with a historical overview of their adoption and adaptation to local conditions. The text then presents detailed case studies of secondary treatment applications, showcasing various configurations and their performance data. Finally, the section explores the established approach of stepped high flows applications, demonstrating how treatment wetlands have been successfully integrated into existing infrastructure to handle both routine treatment and peak flow events. Throughout these examples (**Table 2.1**), the consistent achievement of regulatory standards and the versatility of wetland systems across different scales and wastewater characteristics is highlighted (**Figure 2.1 and 2.2**).



**Figure 2.1.** Performance of treatment wetlands across various applications showing mean and 95%ile effluent concentrations for COD in relation to UWWTR requirements. *Note: these are the only sites in the report that are subject to UWWTR numeric requirements for  $pe > 2,000$ .*



**Figure 2.2.** Performance of treatment wetlands across various applications showing mean and 95%ile (spots) effluent concentrations for BOD in relation to UWWTR requirements. *Note: this includes a combination of sites with  $pe < 2,000$  and  $> 2,000$ , where UWWTR numeric requirements are triggered.*

**Table 2.1** Treatment wetland case studies: Site characteristics and performance summary (1985-2025)

Site ID	Population	Application	Wetland type	Year established	% removal BOD	Effluent BOD (mg/L)	% removal COD	Effluent COD (mg/L)	Effluent NH <sub>4</sub> -N (mg/L)	Notes	Source
1	160	Secondary	SF(ICW)	2021	95	15 (95%ile)	85	111 (95%ile)	41.3 (95%ile)	Wide influent variability	YW datasets
2	120	Secondary and tertiary	Hybrid (FTW+VF+HF)	2013	96	7 (95%ile)	92	28 (95%ile)	8 (95%ile)	Multi-stage system	SW datasets
3	3000	Primary and secondary	HF	1996	93	6 (95%ile)	85	27 (95%ile)	-	UWWTR compliant site	SW datasets
4	941	Primary and secondary	French VF	2014	88	5 (mean)	75	39 (mean)	5.8 (mean)	First UK French wetland	Pereira Gomez (2016) and Khomenko (2019)
5	58	Secondary	Aerated HF	2011	94	5 (median)	--	--	0.8 (median)	Retrofitted with aeration	Butterworth et al (2016)
6	396	Combined high flows and tertiary	Aerated HF	2010	63%*	4 (median)	--	--	0.2	Weak inlet of 11 mg/L BOD	Butterworth et al (2016)
7	30*	Secondary	Aerated VF	2011	--	<25	--	-	<5	High strength influent (BOD 320 mg/L)	ARM website
8	166	Secondary	VF	2013	--	6 (24)	---	--	--	Siphon batch feed system	EA database and ARM website
9	7642	Combined high flows and tertiary	HF	1997	---	6.8 (95%ile)	--	60.3 (95%ile)	5.7 (95%ile)	Long-term operation	EA database
10	972	High flows	SF(ICW)	2022	93	6.6 (mean)	87	28 (mean)	9.9 (mean)	Replaced 850m <sup>3</sup> grey storage	Betts (2023)

Site ID	Population	Application	Wetland type	Year established	% removal BOD	Effluent BOD (mg/L)	% removal COD	Effluent COD (mg/L)	Effluent NH <sub>4</sub> -N (mg/L)	Notes	Source
11	393	Tertiary	Aerated HF	2011	---	5 (median)	--	--	0.1 (median)	Full scale trial	Butterworth et al (2016)
12	91	Secondary and tertiary	French VF	2007	94	9 (95%ile)	94	29 (95%ile)	12.5 (95%ile)	Septic tank + French VF	EA data and Wessex data
A1	1987	High flows	HF	---	--	10 (mean)	--	6 (mean)	--	groundwater impacted catchment	Wessex Water comms
A2	2633	High flows	Aerated VF	--	75	4.2 (mean)	49	26.3 (mean)	2.4 (mean)	Groundwater impacted catchment	Southern Water comms
B1	-	Storm (SPS)	Aerated VF	2014	--	9 (95%ile)	--	---	1.5 (95%ile)	Follows storage	Scottish Water data
B2	-	Storm (SPS)	HF	---						Trial site with river monitoring	Wessex water report

\*Estimated from domestic contribution, based on 150 L/d/pe

## 2.1. General overview of wetlands in the UK

Treatment wetlands have been in use in the UK for secondary and tertiary treatment since a coordinated visit to Europe back in the late 80s with representatives from all water authorities and WRc (Boon 1985). Initially most of these were soil systems based on the German Root Zone Method (e.g. Wessex Water at Marnhull), but it was soon realised that the low hydraulic conductivity of soil caused short circuiting, especially in secondary treatment applications and gravel substrates became the norm. The experience of operating these systems resulted in the first European Guidelines for the use of treatment wetlands published in 1990 (Cooper 1990).

Severn Trent pioneered the use of gravel-based subsurface flow wetlands (“reed beds”), storm overflow dedicated wetlands (“storm reed beds”), and what they called “combined reed beds”. The latter receive a combination of secondary effluent from package treatment plants/trickling filters as well as the storm overflow (typically >6DWF) at the works producing a combined final effluent that meets a numeric consent (Griffin 2004). Severn Trent also trialled and pioneered the adaptation of artificially aerated subsurface flow wetlands (imported to the UK by ARM Ltd) in 2009 (Butterworth et al 2013) and adapted the French Wetland technology for implementation at Hullan Ward in 2015 (Pereira Gomez 2016). In Scotland, there are sites that have operated for over 20 years for secondary and tertiary treatment (Otero and Ergon 2015).

Wessex Water trialled the first demonstration-scale reactive media wetlands in 2009, which were included as part of the second UK Chemicals Investigation Programme for their ability to remove pharmaceuticals. This was followed by Severn Trent in the Packington Low Phosphorus trials (Murujew 2019) and Thames Water’s apatite and steel slag trials (Fonseca 2018). In 2014, Anglian Water and the Norfolk Rivers Trust pioneered the use of surface flow wetlands (“ICWs”) at their Northrepps site, followed by Ingoldisthorpe in 2018 and now extending to Langham and Stifkey. In 2021, Yorkshire Water built the first secondary treatment surface flow wetland in the UK at Clifton STW. Other water utilities also implemented wetlands in different variations (e.g., modular wetlands at Anglian and Severn Trent) before the most recent interest in surface flow systems for nutrient neutrality and storm overflows. Exemplar case studies are detailed below, with additional studies and applications included in [Appendix B](#).

## 2.2 Secondary treatment

### *National Guidance for secondary treatment wetlands*

The CWA has produced guidelines for the design of conventional vertical flow wetlands for treating small domestic discharges. The design has been based on 15 years of UK experience and will produce an effluent of 20/30/20 mg/L (BOD/TSS/NH<sub>4</sub>-N) when fed from a conventional septic tank. They were developed by a team of wetland professionals and peer reviewed by the international wetland community (Weedon et al 2017).

In Ireland, ICWs are a standard technology for delivering secondary treatment. Their guidelines were published in 2010, and monitoring has shown that they can bring very high strength wastewater loads (>1,000 mg/L COD) to well within UWWTD standards with very low indicator organism counts (DEHLG, 2010).

Outside the UK & Ireland, national design standards for secondary treatment applications exist for Denmark, Germany, Austria, and the USA, among others (Dotro et al 2017).

## Case studies

### Site 1: Integrated Constructed Wetland, Clifton (Yorkshire Water), 160 pe

As part of capital maintenance and an impending TP target on a descriptive works, Yorkshire Water implemented the first surface flow wetland (ICW) for secondary treatment at Clifton STW (Site 1), which serves a population of 160. It has a primary tank followed by five cells. Cell 1 has been taken out of operation, and cells 2 and 3 operate in parallel. Their combined effluent feeds cell 3, which then feeds cells 4 and 5, as and when water flows require them to deliver treatment. It has a consent of 4 mg/L TP but is descriptive for sanitary pollutants (i.e., not designed to achieve a specific BOD or COD numeric consent). The wetland was commissioned in October 2021 and has been sampled by YW as part of the trial agreed with the EA, with 26 matched inlet-outlet samples analysed over 669 days (Jan 23 – Nov 24; **Table 2.2**). The 95%ile values for effluent BOD and COD are 15 mg/L and 111 mg/L, respectively, despite influent values of 372 mg/L and 731 mg/L, respectively. This translates to 95% removal efficiency for BOD and 85% for COD from the *inlet of the wetlands*, showing compliance with UWWTR for secondary treatment (concentration and removal based). It should also be noted the Clifton works has occasional no flows in the outlet as the cells have been designed to fill progressively. This can result in samples that are concentrated in the final effluent when there is high evapotranspiration.

**Table 2.2. Influent and effluent characteristics for Clifton STW (Jan 2023 – Nov 2024; n = 26)**

Parameter	Inlet to wetland (mg/L)			Outlet (mg/L)			% Removal
	95%ile	Min	Max	95%ile	Min	Max	
COD	731	193	769	111	33	118	85
BOD	312	50	376	15	2	39	95
NH <sub>4</sub> -N	78.6	21	84	41.3	7	43	47

### Site 2: Hybrid system, Site A (Scottish Water), 120 pe

In 2011, Scottish Water were required to upgrade a septic tank rural works and, with SEPA's agreement, developed a trial based on a multistage wetland to deliver enhanced treatment. The flowsheet consisted of a septic tank, an "interceptor" and four sets of wetlands, in the following order: one floating wetland (primary treatment), one conventional horizontal subsurface flow wetland (primary treatment), two sets of parallel vertical flow wetlands in series (secondary treatment), and a set of parallel horizontal flow wetlands for polishing and biodiversity value. The specific area sizing for the entire wetland treatment system was 5.3 m<sup>2</sup>/pe. The flowsheet was commissioned in 2013 and intensively monitored for performance during the first three years (**Table 2.3**). The trial provided learning in terms of the risk of solids washout from septic tank/interceptor onto the downstream wetlands during high flows (DWF = 34 m<sup>3</sup>/d; FFT = 260 m<sup>3</sup>/d) but also showed the robustness of the wetlands to deal with wide variations in flow and load, achieving removals of 96% and 92% for BOD and COD, respectively, and 80% removal for both TSS and ammonia.

**Table 2.3 Performance of multi-stage wetland system at Site A (2013-2016; n =201)**

Parameter	Inlet to wetland (mg/L)			Outlet (mg/L)			% Removal
	95%ile	Min	Max	95%ile	Min	Max	
<b>COD</b>	356	27	1916	28	10	69	92
<b>BOD</b>	154	7	741	7	2	13	96
<b>TSS</b>	128	8	1385	26	2	103	80
<b>NH<sub>4</sub>-N</b>	41.9	3	53.4	8	0.5	14.6	81

Note: The wide range between minimum and maximum influent values (e.g., BOD 7-741 mg/L, COD 27-1916 mg/L) demonstrates the system's resilience to high loading events while maintaining consistent effluent quality

*Site 3: Horizontal flow, Site B (Scottish Water), 3000 pe*

Built around 1996, this site serves a population of 3,000 pe. It consists of preliminary treatment and two horizontal flow wetlands in parallel. It has a consent for UWWTR regulations (25 mg/L BOD and 125 mg/L COD) as well as a 100 mg/L TSS consent. This means the wetlands are performing both primary and secondary treatment. The network has significant infiltration, resulting in average per capital flows of 400 L/d (instead of SW's average of 180 L/d). Historic performance data from 2014/5 based on seven matched pairs of inlet and outlet composite samples show average 93% and 85% removal efficiencies for BOD and COD (**Table 2.4**). Average effluent values were 3 and 19 mg/L for BOD and COD, respectively. Based on 13 spots samples in the same period, 95%ile effluent values were 10 and 30 mg/L for BOD and COD, respectively.

**Table 2.4 Summary of performance at Site B based on composite samples.**

Parameter	Inlet to wetland (mg/L)		Final effluent (mg/L)		% Removal*
	Mean	95%ile	Mean	95%ile	
<b>COD</b>	133	266	20	27	85
<b>BOD</b>	40	92	3	6	93

\*Based on seven matched samples

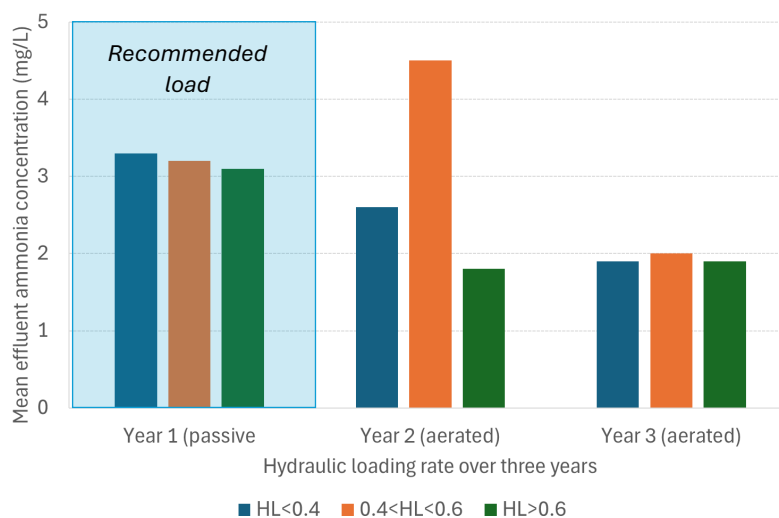
*Site 4: French wetland systems in the UK – Hulland Ward (Severn Trent), 941 pe*

In 2014, Cranfield University facilitated the introduction of French wetland technology to the UK in collaboration with Severn Trent, MWH and ARM. Hulland Ward was chosen as the first full-scale trial site, serving a population of 941 people and needing to achieve a 30/50/15 mg/L BOD/TSS/NH<sub>4</sub>-N consent. The site previously had trickling filters that were at the end of their life cycle. The solution was a conventional French Wetland installation, i.e., three gravel-based parallel VF beds for combined sludge and primary treatment, and two parallel VF wetlands for secondary treatment. Because the technology originated from France, Cranfield had two projects to help with developing the adaptations of the design to suit UK conditions. As part of that, the team compared composite samples taken at inlet, after primary (wetland) treatment, and at the outlet of the secondary wetland (final effluent) over five months, three times a week (**Table 2.5**), to compare against systems in France.

**Table 2.5. Performance of secondary treatment wetland based on composite samples July – December 2015 (Pereira Gomez 2016)**

Parameter	Inlet to 2ry wetland (mg/L)			Final effluent (mg/L)			% Removal
	Mean	St Dev	Samples	Mean	St dev	Samples	
BOD	46	18	32	5	1.7	32	88
COD	169	59	36	39	11.3	33	75
NH <sub>4</sub> -N	28	7	32	5.8	3.8	39	78
TSS	56	21	35	6	2.5	34	88

The system received significantly higher flows than the proven French design hydraulic loads of 0.37 m<sup>3</sup>/m<sup>2</sup>/d (**Figure 2.3**). In year two, the second stage was retrofitted with artificial aeration and only one bed in the second stage has been in use since then. The biggest difference has been observed in effluent ammonia, with 95%ile values of 9.6 mg/L in passive mode and 5.3 mg/L as 95%ile once forced aeration was introduced (Khomenko 2019). The system has been able to cope with hydraulic loads higher than design with the addition of aeration into half the footprint for the second stage.



**Figure 2.3** Effluent ammonia obtained from French wetland depending on the hydraulic load received by the system. The maximum hydraulic load recommended is 0.37 m<sup>3</sup>/m<sup>2</sup>/d.

*Sites 5 and 6: Aerated secondary wetlands, Severn Trent, 58 and 396 pe*

In 2009, Severn Trent engaged ARM to retrofit artificial aeration in a few selected rural works that had an ammonia (quality) driver. With Cranfield University and co-funded by EPSRC, a PhD project conducted intensive monitoring of four key works and produced a number of peer reviewed publications. Of relevance here are two sites: Site D, which was the only secondary treatment wetland in the study and Site B, which was a combined wetland site that experienced a catastrophic secondary treatment process failure and treated all flows during ~50 days (Butterworth et al 2016).

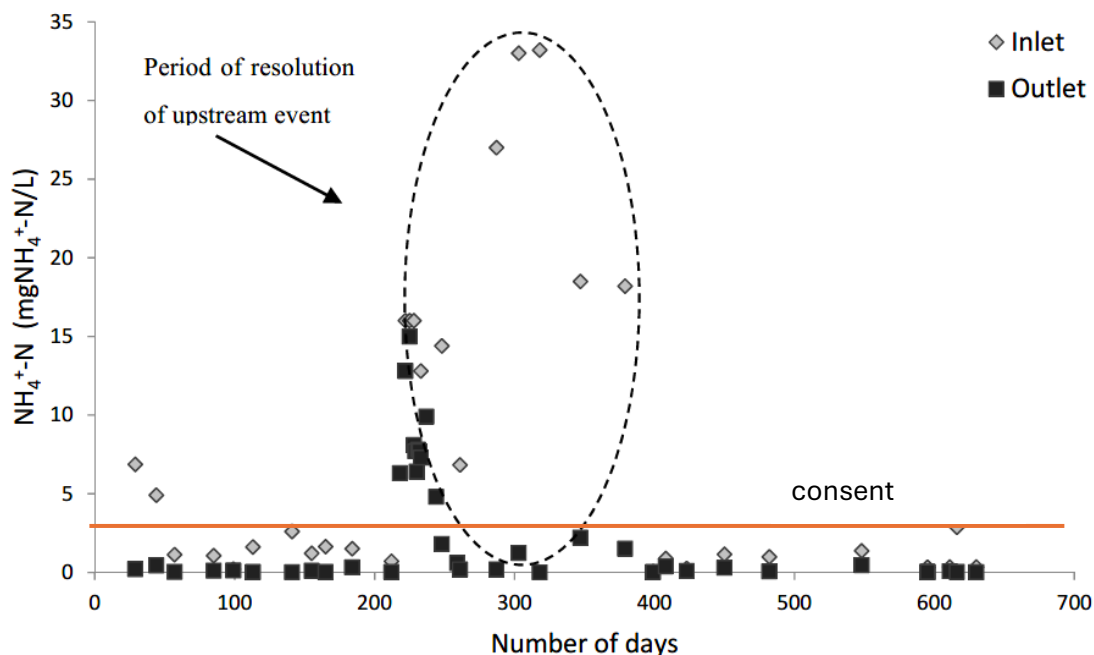
Site 5 (Site D in the paper) was retrofitted with aeration in March 2011, and consisted of a septic tank followed by a secondary subsurface flow wetland. The site serves 58 pe and had a descriptive consent. The driver for the aeration was reducing the occurrence of sewage fungus

and minimising corrosion from the anaerobic systems onsite, as the bed was significantly undersized. Results for the studied period confirmed the site was delivering effluent BOD < 21 mg/L and either fully or partially nitrifying (Table 2.6).

**Table 2.6 Summary of performance at Site D: Secondary aerated wetland (Adapted from Butterworth et al 2016).**

Parameter	Inlet to wetland (mg/L)			Final effluent (mg/L)			Sample size	% Removal
	Median	Min	Max	Median	Min	Max		
BOD	79	40	98	5	2	21	19	94
TSS	57	10	150	20	4	90	17	65
NH <sub>4</sub> -N	29.4	1.0	59.6	0.8	0.1	2.6	16	97

Site 6 (Site B in the paper) was a single integrated RBC followed by a single combined wetland, serving a population equivalent of 396. It was retrofitted with aeration in October 2010 as a new ammonia consent came into force, requiring the works to deliver 14/45/3 for BOD/TSS/NH<sub>4</sub>-N. The site's RBC failed during the monitoring period during the winter, when water temperatures averaged 9.5 to 13°C. The wetland went from receiving influents of < 5 mg/L NH<sub>4</sub>-N to 33 mg/L NH<sub>4</sub>-N. After ten days, the wetland was able to treat this increased load, producing an effluent NH<sub>4</sub>-N sub 1 mg/L after 30 days despite influent concentrations between 15 and 35 mg/L (Figure 2.4).



**Figure 2.4.** Resilience of aerated wetland to increased ammonium loading following upstream treatment failure. Influent concentration went from < 5 mg/L to 33 mg/L. The wetland increased its removal rate, producing fully nitrified effluents within 30 days. *Butterworth et al (2016).*

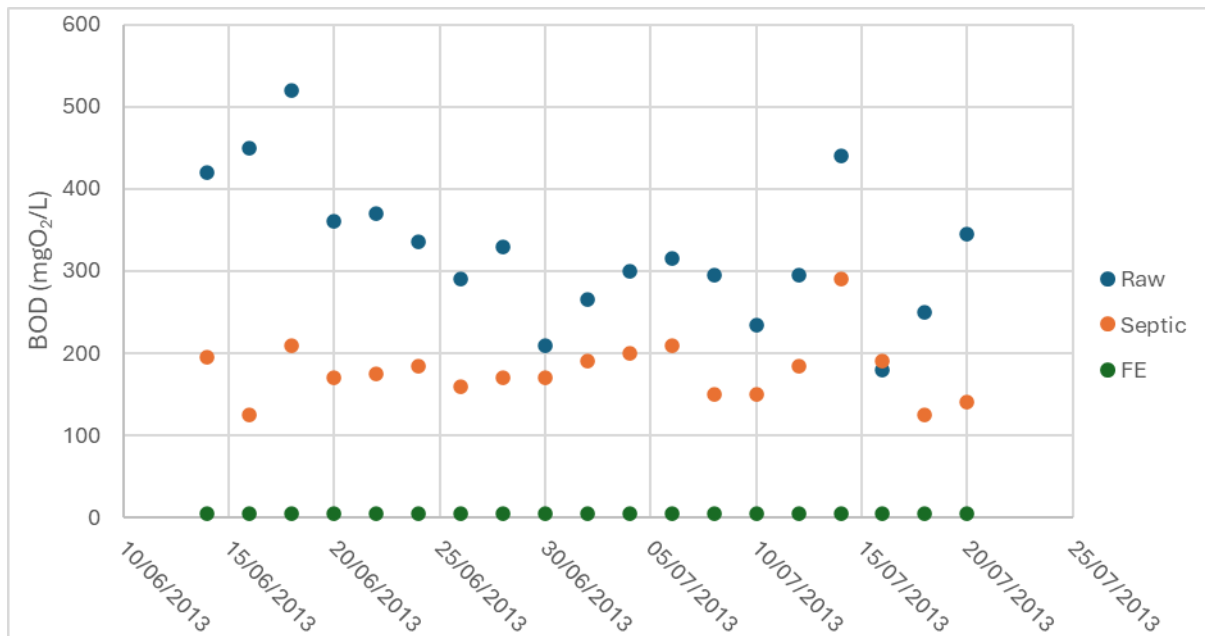
*Site 7: Aerated saturated vertical flow, Balhall (Scottish Water), 30 pe*

This site was designed and installed by ARM Ltd after Scottish Water identified the need for an upgrade to a small WWTW in 2011. The treatment wetlands provide secondary treatment for

4.7 m<sup>3</sup>/d of sewage plus runoff (peak 37.8 m<sup>3</sup>/d), with primary treatment in a septic tank. Two wetland beds (171 and 25 m<sup>2</sup>) have been reported to bring the strong load (BOD 320 mg/L and NH<sub>4</sub>-N 42.7 mg/L) to within discharge consents of 25 and 5 mg/L for BOD and NH<sub>4</sub>-N respectively (ARM undated p20).

*Site 8: Vertical flow wetland, Lower Basildon (Thames Water), 166 pe*

This vertical flow wetland also follows a septic tank as a primary stage and is designed to treat 31 m<sup>3</sup>/d (ARM undated). The 684 m<sup>2</sup> treatment wetland is fed in batches by a siphon. Data obtained from ARM presented the results at commissioning, showing a reduction from the septic tank's effluent BOD of 200 mg/L BOD to <5 mg/L (**Figure 2.5**). Analysis of records from the EA database for this site between 2015 and 2024 showed mean and 95%ile effluent BOD values of 6 mg/L and 24 mg/L, respectively, based on 17 samples.



**Figure 2.5** Composite sample results for BOD at site 8, showing crude, septic (inlet to wetland) and final effluent (post wetland) concentrations. *Chart based on data from commissioning (ARM).*

*Site 12 (March 2025): French VF secondary treatment following a septic tank, Alderton (Wessex Water), 91 pe*

This small rural works was built as a first-time sewerage scheme in 2007. The flowsheet consists of a septic tank followed by a classical French VF configuration (3 cells in parallel, only one in operation at any given point; followed by 2 cells in parallel, only one in operation at any given point). Performance data was obtained via a query to Wessex Water and combined with EA records. Results showed 94% removal of COD based on 25 composite samples, with 95%ile effluent concentrations of 42 mg/L. For BOD, the removal efficiency based on 52 composite samples was 94%, with a 95%ile final effluent concentration of 15 mg/L (**Table 2.7**).

**Table 2.7** Summary performance of flowsheet at site 12 (2017 – 2025)

Parameter	Crude (mg/L)			Final effluent (mg/L)			% Removal
	Mean	95%ile	Samples	Mean	95%ile	Samples	
<b>COD</b>	465	1066	25	29	42	34	94
<b>BOD</b>	149	368	52	8.5	15	121	94
<b>NH<sub>4</sub>-N</b>	33.4	64.7	52	12.5	31	123	63
<b>TSS</b>	165	469	52	7.7	16	123	95

### *Severn Trent's secondary horizontal flow wetlands*

Following the introduction of horizontal flow wetlands in Severn Trent in the late 80s, in 2005 nineteen sites were evaluated to determine performance after years of operation, with the oldest bed built in 1987 (18 years at the time of measurement; Baggaley and Griffin 2005). By then, Severn Trent was recommending parallel beds wherever possible, sized at a minimum of 5 m<sup>2</sup>/pe. Although the company later removed horizontal flow wetlands as a template solution for secondary treatment systems due to their anaerobic nature, they are presented here as they did meet UWWTR discharge standards (**Table 2.8**).

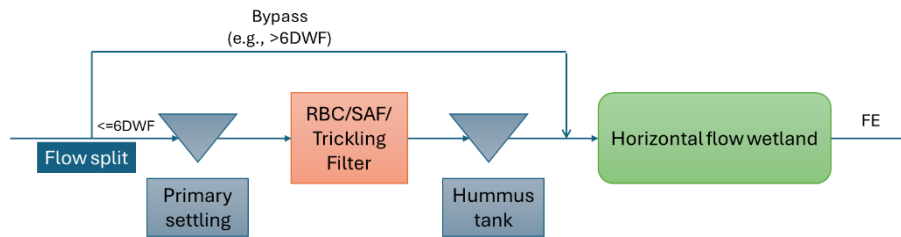
**Table 2.8.** Long-term final effluent data from 19 secondary horizontal flow wetlands in the Severn Trent region (1987-2005; Baggaley and Griffin 2005)

Parameter	All sites		Single beds		Two in series	
	BOD	TSS	BOD	TSS	BOD	TSS
<b>Mean (mg/L)</b>	9	23	20	23	5	21
<b>Max (mg/L)</b>	41	50	41	50	12	46
<b>Min (mg/L)</b>	1	3	8	10	1	3
<b>Number</b>	28	30	8	9	16	16

## 2.3 Stepped high flows applications for secondary and tertiary treatment

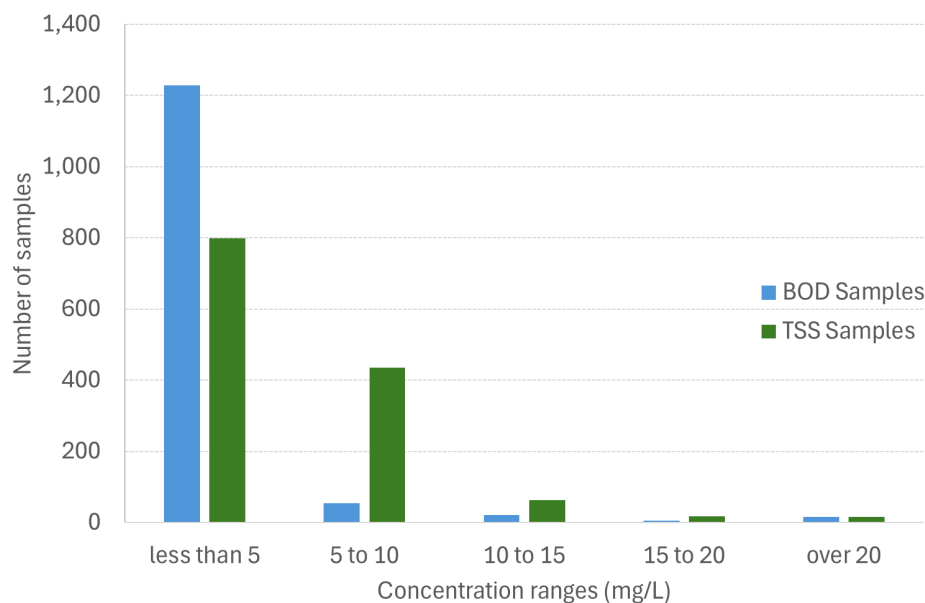
### *Combined final effluent streams*

This approach has been in use since the introduction of wetland technology to the UK in the late 80s/early 90s. There are many examples across England, Wales and Scotland with this setup, where flows exceeding a certain DWF multiplier are diverted to the inlet of the tertiary treatment wetland (“reed bed”), blending with secondary treated effluent for combined treatment. The FE sampling point is downstream of the wetland (example on **Figure 2.6**).



**Figure 2.6. Schematic flow diagram of a combined reed bed system showing treatment pathways for normal and high flows.** During flows up to six times the dry weather flow will undergo treatment through an integrated rotating biological contactor (RBC) and a horizontal flow wetland; at flows higher than 6DWF, the excess will bypass primary and secondary treatment and blend with secondary effluent before entering the tertiary wetland.

As of 2003, Severn Trent had 52 rural works with combined and tertiary wetlands. An analysis of their final effluent records showed consistently good performance, delivering BOD < 5mg/L and TSS < 10 mg/L (Griffin, 2004; **Figure 2.7**). Site 9 is an example of this arrangement for a medium sized works.

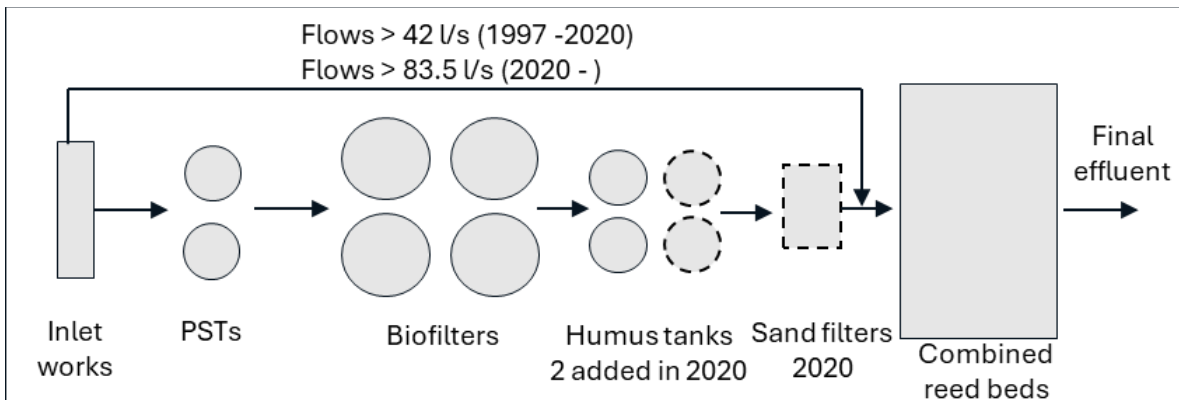


**Figure 2.7. Distribution of BOD and TSS in effluent from 52 combined reed bed sites (1999-2002; adapted from Griffin 2004).**

*Site 9: Large combined reed bed, Shipston-on-Stour (Severn Trent), 7600 pe*

This mature site has had a stepped-high-flows combined wetland since 1997 and serves a population equivalent of 7,642. The flowsheet consists of primary settling tanks, trickling filters, hummus tanks and combined wetlands (“reed beds”). The wetlands receive secondary treated effluent from the main flowsheet up to 42 L/s. Flows above this value and up to 106.5 L/s bypass primary and secondary treatment and are solely treated by the wetland (**Figure 2.8**). The site was upgraded in 2019 to meet a phosphorus consent with the addition of tertiary treatment, so

results are summarised for the period before the upgrade, for composites (UWWTR compliance) and spots (**Table 2.9**).



**Figure 2.8 Flowsheet for Site 9, serving 7600 pe, showing tertiary wetlands receiving a combination of secondary effluent and screened sewage during high flows. Courtesy of Severn Trent.**

**Table 2.9** Summary of data between 2010 – 2018 as extracted from EA database

Parameter	Composites			Spots		
	Outlet (mg/L)		Sample size	Outlet (mg/L)		Sample size
	Mean	Max		Mean	95%ile	
<b>COD</b>	40.9	64	36	-	-	-
<b>BOD</b>	2.6	9	36	2.8	6	108
<b>NH<sub>4</sub>-N</b>	-	-	36	2.3	5.7	108

### Separate high-flows treatment

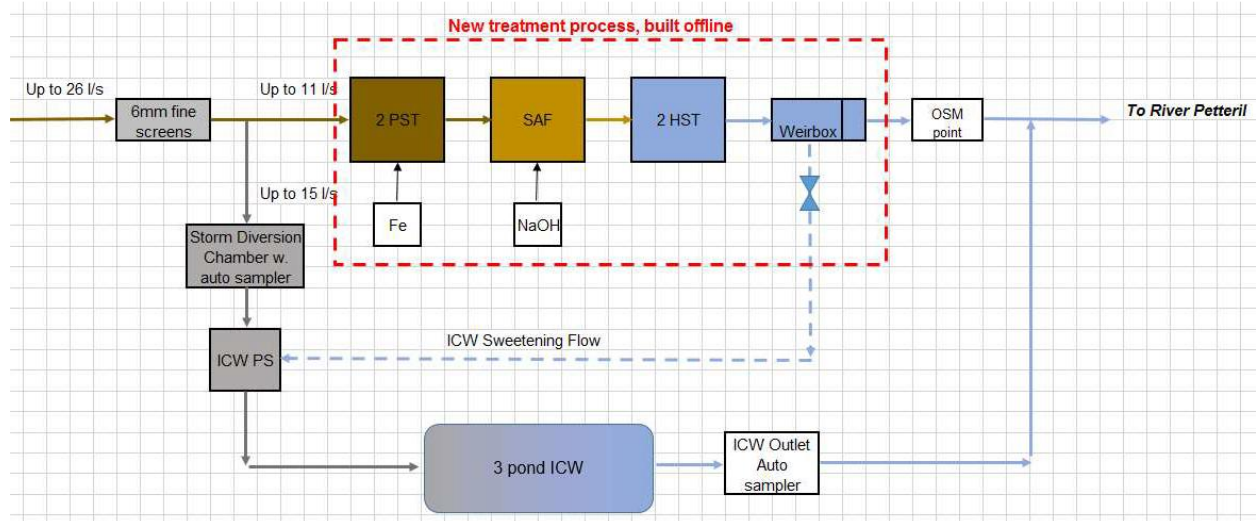
Severn Trent also trialled separate “storm” beds at the works, which were dedicated to replacing storm tanks and treat solely storm overflows, with a separate discharge point. Whilst the beds were effective in biologically treating wastewater (Griffin 2004), the company found the reeds struggled during the long periods where they received no influent and looked unhealthy. Rather than bleed wastewater constantly to top up the storm beds, they switched to the combined reed bed flowsheet described in the previous section. This meant a better utilisation of both the assets, as the beds were in continuous operation, and land (Griffin 2004).

In recent years, new stepped high-flows flowsheets have been trialled by other companies with different types of wetlands. In these cases, the separate wetland treated effluent is blended with secondary treated sewage prior to the discharge point (rather than before tertiary treatment or having a separate storm discharge point).

### Site 10: Surface flow wetland side treatment, Southwaite (United Utilities),

This works treats all flows (no storm outfall permit, all flows to undergo biological treatment) with a flow range of 1 to 26 l/s (1 in 30-year flow). A 3-cell surface flow wetland (ICW) receives up to 15 l/s and replaced what would have been 850 m<sup>3</sup> grey storage whilst treating screened flows to the required standards (**Figure 2.9**). A snapshot of data was presented by UU at the European Water and Wastewater

Management Conference in 2023 (Betts 2023; **Table 2.10**).



**Figure 2.9. Flowsheet showing dedicated storm bed for stepped high flows. From Betts 2023.**

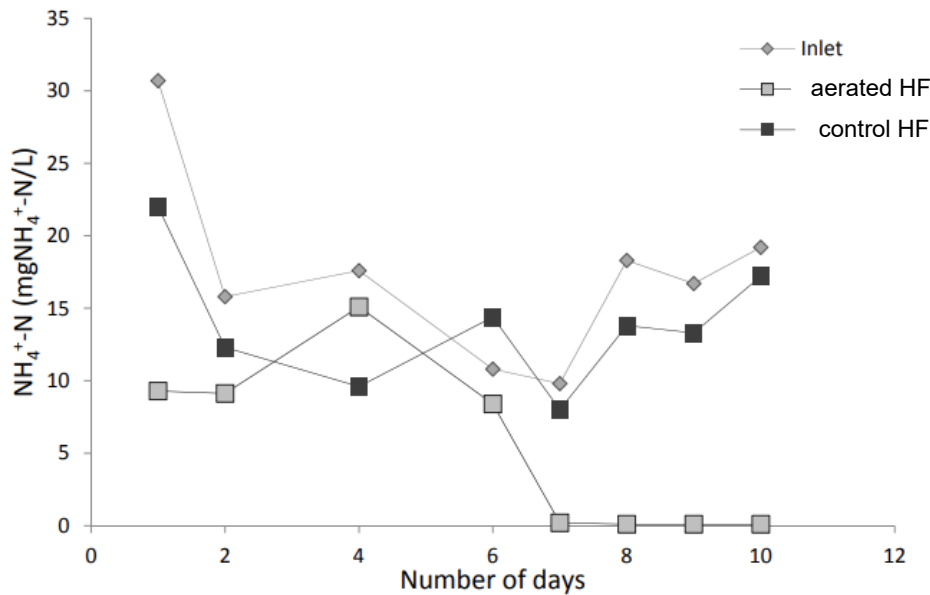
**Table 2.10** Summary of performance for storm bed at UU (Betts 2023)

Date	Inlet BOD (mg/L)	Outlet BOD (mg/L)
27/07/22	-	23.9
22/09/22	464	21.7
01/10/22	398	11.3
06/10/22	271	28
10/01/23	37.5	35
11/01/23	64.5	17
<b>Average</b>	<b>247</b>	<b>22.8</b>

**Additional examples of sewer overflow/dedicated storm beds applications can be found in Appendix B.**

*Site 11: Tertiary treatment, aerated horizontal flow, Gaulby (Severn Trent), 393 pe*

This site was part of a controlled trial at full-scale in Severn Trent, reported as “site A” by Butterworth et al (2016). The site has been included here as it shows how quickly a system that has a dormant population of nitrifiers can be re-started (**Figure 2.10**). It consists of a primary settling tank followed by a submerged aerated filter. Tertiary treatment is via two parallel HF wetlands with a separate storm bed that receives the wastewater exceeding six times the dry weather flow. The tertiary systems are of equal size, with aeration fitted in March 2011 to both beds. The aeration was turned on in one bed and left dormant in the control bed. The beds at this site were disconnected for 5 months (December 2011–April 2012) due to mechanical maintenance of the secondary treatment during which time the flow was removed from site.



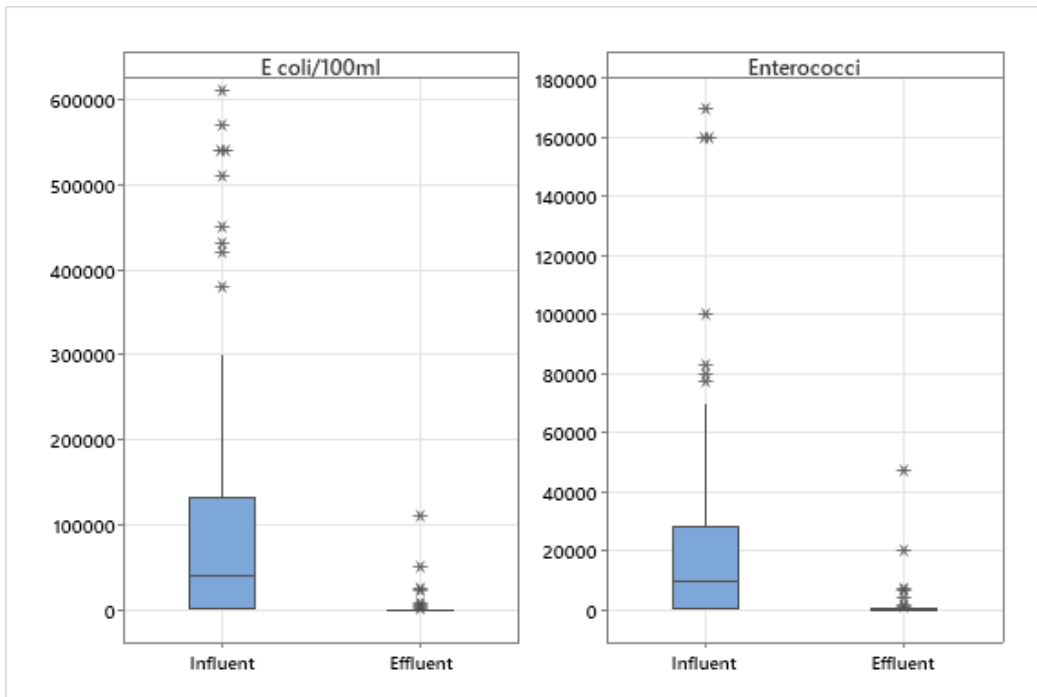
**Figure 2.10.** Concentrations of ammonia entering both wetlands (inlet) and effluent from the aerated HF bed and non-aerated control bed following five months of being starved off wastewater. The systems took a week to achieve complete nitrification in the system with aeration whereas the control bed remained at low removal efficiencies due to lack of oxygen.

### 3 Pathogen removal

A key part of the current public concerns about wastewater and combined sewer overflows (CSOs) discharges to the environment is the exposure of water users to pathogens and bacteria with anti-microbial resistance. In addition to removal of organic matter and ammoniacal-N, treatment wetlands can contribute removals of indicator bacteria and viruses from wastewater. This results from a variety of processes such as adsorption, inactivation, and predation. These removals tend to be similar to grey infrastructure and often can enhance removals in previous processes, especially when deployed as tertiary treatment systems.

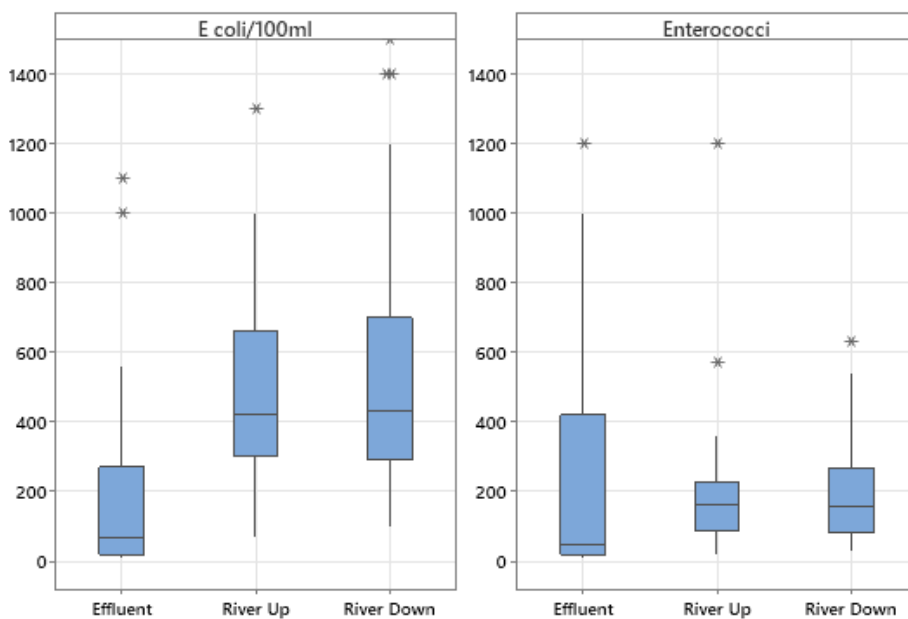
Subsurface treatment wetlands for secondary treatment generally remove 2 – 3 log orders (99-99%) of indicator bacteria and this translates into similar removals of pathogenic bacteria and viruses (Dotro et al., 2017). This is also seen in aerated tertiary wetlands which can give an additional >1 log removal from already well treated effluents (Stefanakis et al., 2019) giving effluents in the 1-2 log range for E coli. In Germany, France and Italy CSO wetlands have also been reported to give 1-2 Log reductions in faecal indicator counts in lab and field studies from typical inlet values of 10<sup>4</sup> to 10<sup>6</sup> MPN or CFU·100 mL<sup>-1</sup>, with much higher removals reported for specific events and separate sewer systems (Ruppelt et al 2020).

Similar removals are seen in wetlands treating CSOs in groundwater affected catchments. For example, the E coli and Enterococci counts in the CSO treatment wetland at Hanging Langford (Site B2) are reduced between inlet and outlet (**Figure 3.1**), as per data supplied by Wessex Water. More details on this site can be found in [Appendix B](#).



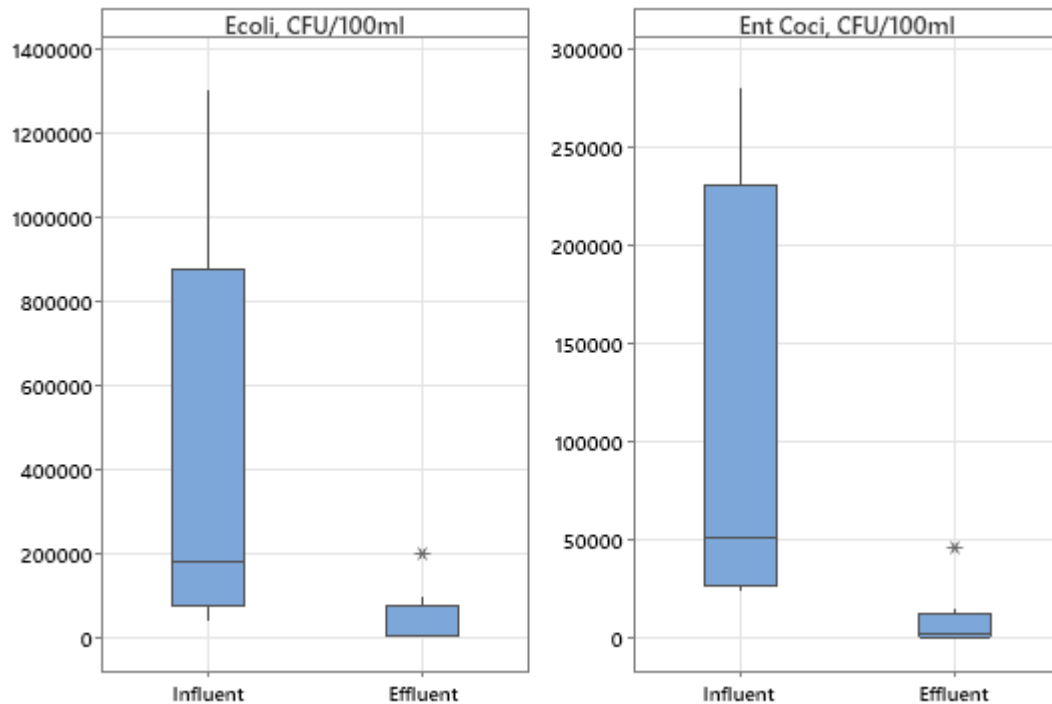
**Figure 3.1.** E coli and Enterococci counts in CSO treatment wetlands inlet and outlets at Hanging Langford (2 influent outliers have been truncated).

The wetland consistently provides 1-3 Log orders reduction in indicator organism counts but also has lower median counts than the receiving watercourse (70 vs 430 E Coli/100 ml and 50 vs 160 Enterococci/100ml) with both the effluent and the river having similar maximum values (Figure 3.2).



**Figure 3.2** E coli and Enterococci counts in CSO treatment wetlands effluent compared to river values (some outliers have been truncated).

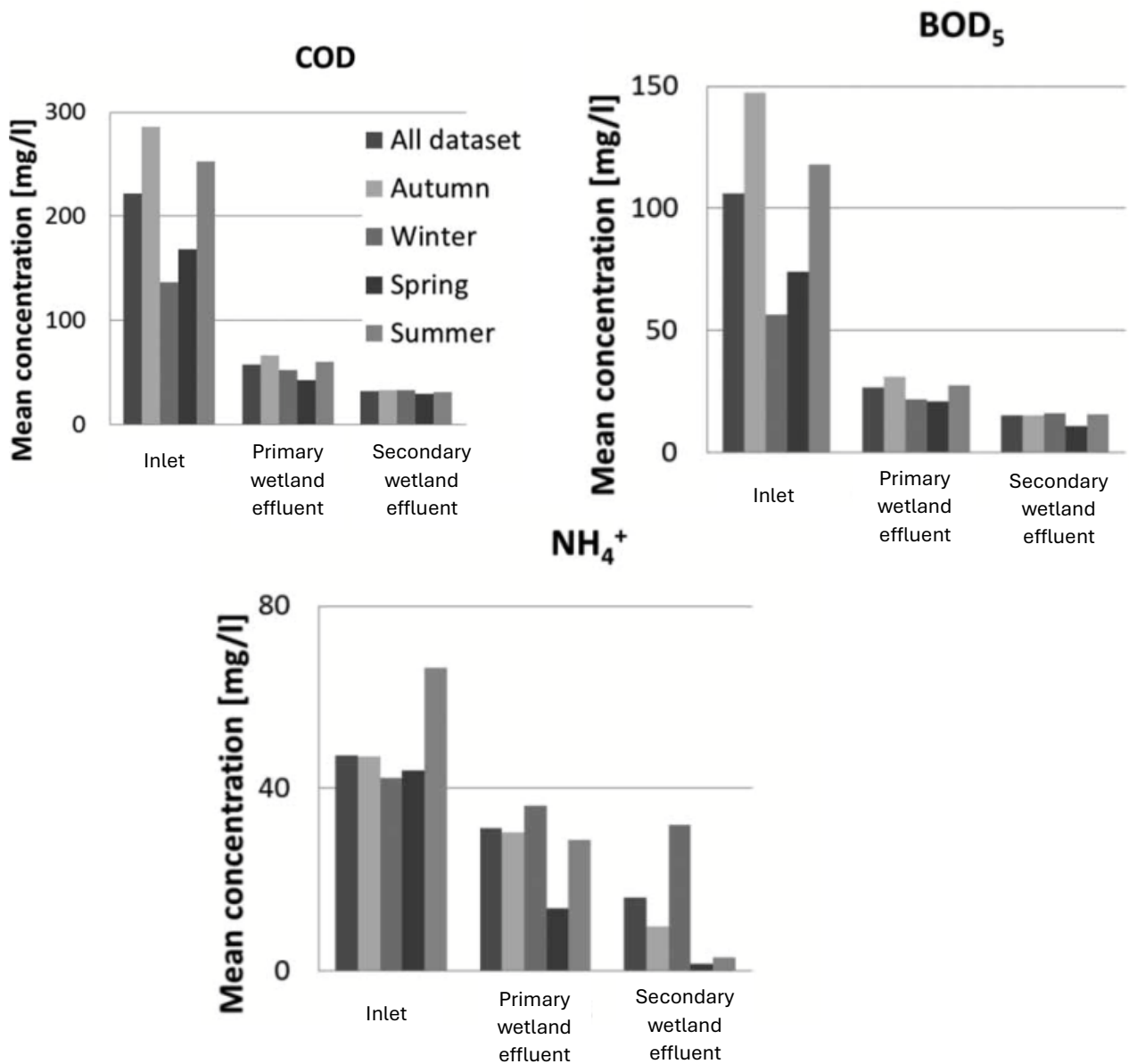
Southern Water’s aerated CSO wetland at Lavant (Site A2) has also shown between 1.5 and 2.5 Log order reductions in indicator organisms (**Figure 3.3**) with median effluent values of 6500 and 1800/100mL respectively for E coli and Enterococci.



**Figure 3.3** E coli and Enterococci counts in Lavant’s CSO treatment wetlands inlet and outlet.

## 4 International experience

This report is concerned with biological treatment with engineered wetlands and their ability to meet UWWTR based on UK experience. As most wetlands for secondary treatment in the UK are serving less than 2,000 pe, Site 13 is introduced here, which is located in Moldova and serves a population equivalent of 20,000 pe. The site and its monitoring are detailed in Masi et al (2017), with key performance charts summarised in **Figure 4.1** and **Table 4.1** for the first two years of operation. Notably, the system is located in an area with air temperatures of 45°C in summer and -27°C in winter, illustrating the wetlands’ ability to deliver secondary treatment even under extreme weather conditions.



**Figure 4.1.** Summary of performance over a full year for a French style wetland, showing full year datasets and their changes with season. Compliance with UWWTD is achieved year-round, producing a partially nitrified effluent.

**Table 4.1** Summary of performance of the entire wetland-based flowsheet. Adapted from Masi et al (2017).

Parameter	Influent	Effluent	% removal
COD (mg O <sub>2</sub> /L)	222	32	85
BOD (mg O <sub>2</sub> /L)	106	15	86
NH <sub>4</sub> -N (mg/L)	47	16	67

## 5 Discussion

---

The case studies presented in this report provide compelling evidence for treatment wetlands as effective biological treatment systems, whilst also highlighting several important methodological considerations for data interpretation and performance evaluation. It should be noted that this compilation represents only a subset of the available data, with water utilities likely holding additional operational records including flow measurements, online monitoring data for parameters like ammonia (which serves as a useful surrogate for biological treatment assessment), and long-term performance trends. Such comprehensive datasets would enable more detailed analysis of treatment efficacy across varying conditions and could form the basis for a more extensive industry-wide review in the future.

It should also be noted that most secondary treatment case studies calculated removal percentages based on the *inlet to the wetlands* (typically primary effluent) rather than crude sewage, while regulations typically require crude-to-final effluent calculations. This difference in calculation basis is important when comparing performance to regulatory standards. Notably, the wetland systems demonstrate percentage removals that meet Urban Wastewater Treatment Regulations even when calculated from a lower starting concentration point (primary effluent) than would be used in regulatory calculations (crude sewage). This suggests that the actual overall treatment performance from crude to final effluent would likely exceed regulatory requirements, further strengthening the evidence for wetlands' effectiveness as biological treatment systems.

Whilst the focus of this report is on secondary treatment applications, case studies on storm overflow applications were summarised. In these cases, the influence of dilution in groundwater-impacted catchments affects performance metrics. Whilst percentage removal calculations may appear lower due to already diluted influent, the absolute effluent concentration often meets or exceeds requirements. This highlights the importance of placing effluent concentrations in context of the wetlands' mass removal rates (which require flow measurements) for a complete performance assessment and benchmarking with literature.

Additionally, comparing event-based performance (such as storm overflow treatment) to steady-state systems presents challenges in data interpretation. Storm systems experience intermittent loading, varied retention times, and significant flow fluctuations that steady-state systems do not, yet the data shows they can still provide effective biological treatment.

After four decades of experience with various wetland configurations across the UK, the time is right to develop standardised design guidelines for UK applications. The Constructed Wetland Association aims to address this need in 2025, building on the substantial body of evidence presented in this report and leveraging international best practices adapted to UK conditions.

## 6 Conclusions

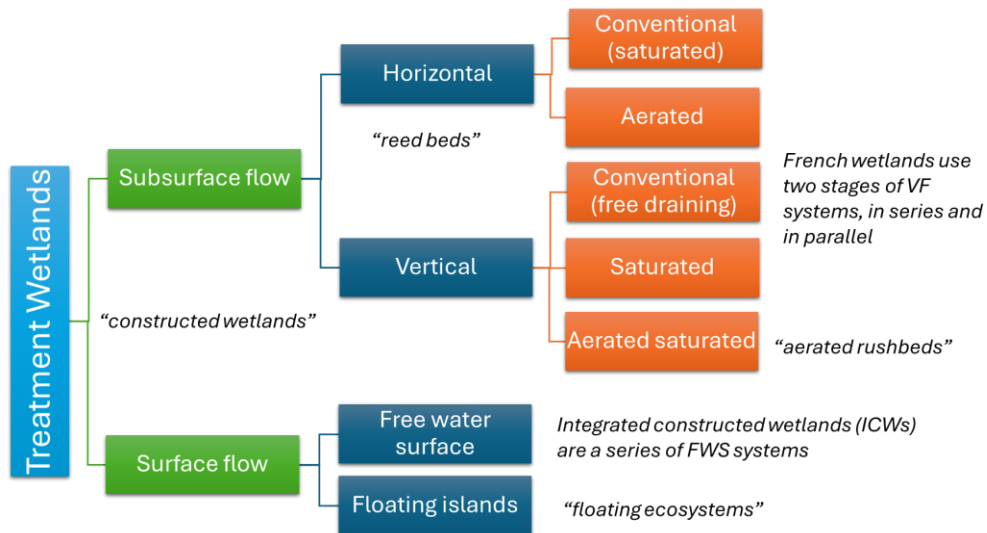
---

Treatment wetlands are an established biological treatment technology, successfully implemented in many applications throughout the UK over the past four decades. The UK pioneered the use of gravel substrates for horizontal flow wetlands in the early 1990s, demonstrating early innovation in this field. Evidence presented in this report confirms successful deployment of all major technology variants (horizontal flow, vertical flow, surface flow, and French wetland designs) for sewage applications, including stepped high flows at sewage treatment works and for CSO management within networks.

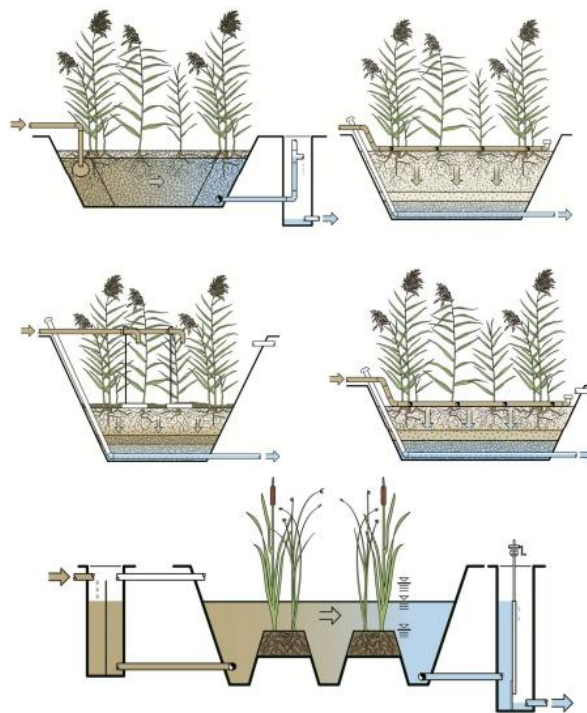
Experience from both the UK and European countries consistently demonstrates that treatment wetlands deliver secondary treatment meeting or exceeding Urban Wastewater Treatment Regulations requirements. This performance remains consistent regardless of population size served or treatment process stage. The 40-year track record of treatment wetlands in the UK represents a significant body of evidence supporting their role as established biological treatment systems for wastewater management.

## Appendix A. Overview of treatment wetland terminology

The simplest classification of treatment wetlands is based on their water table and direction of flow (**Figure A1**). Profile schematics of each main variation were summarised in Dotro et al (2017) and are reproduced below (**Figure A2**).



**Figure A1.** Standard classification of treatment wetlands and colloquial names associated with key technology variations



**Figure A2.** Main types of treatment wetlands: Top Left – Horizontal Flow; Top Right – Vertical Flow; Middle Left – French First Stage; Middle Right – French Second Stage; Bottom –Surface Flow (Dotro et al 2017)

## Appendix B. Summary of case studies for storm overflow applications

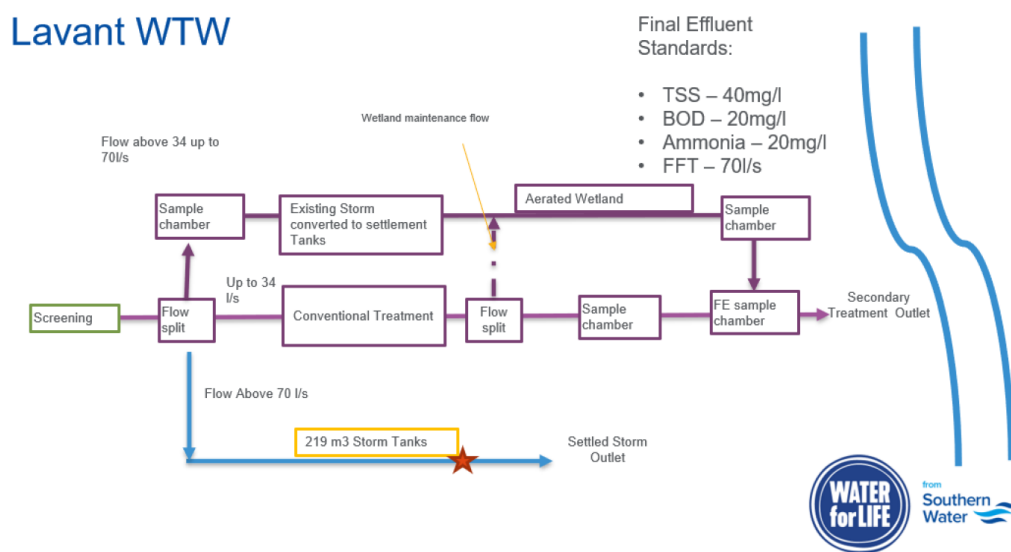
### A. Groundwater impacted storm overflow treatment systems

#### Site A1: Shrewton. Wessex Water

Shrewton WRC (1,987 pe) inflow is heavily influenced by groundwater ingress with 139 spills over 2969 hours in 2022. Wessex have undertaken a programme of sewer sealing (1.7 km) but own less than a 1/3 of the network, they still calculate that 129,000 m<sup>3</sup> of storage would be required, dwarfing the plant. A TW has been constructed to treat storm flows. The reed bed effluent reported by Wessex over the winters of 2022 and 23 have approximately 10 mg/L BOD and 6 mg/L mg-N/L NH<sub>4</sub>-N compared to permits of 45 and 15 mg/L respectively (Wessex per comm., 2024).

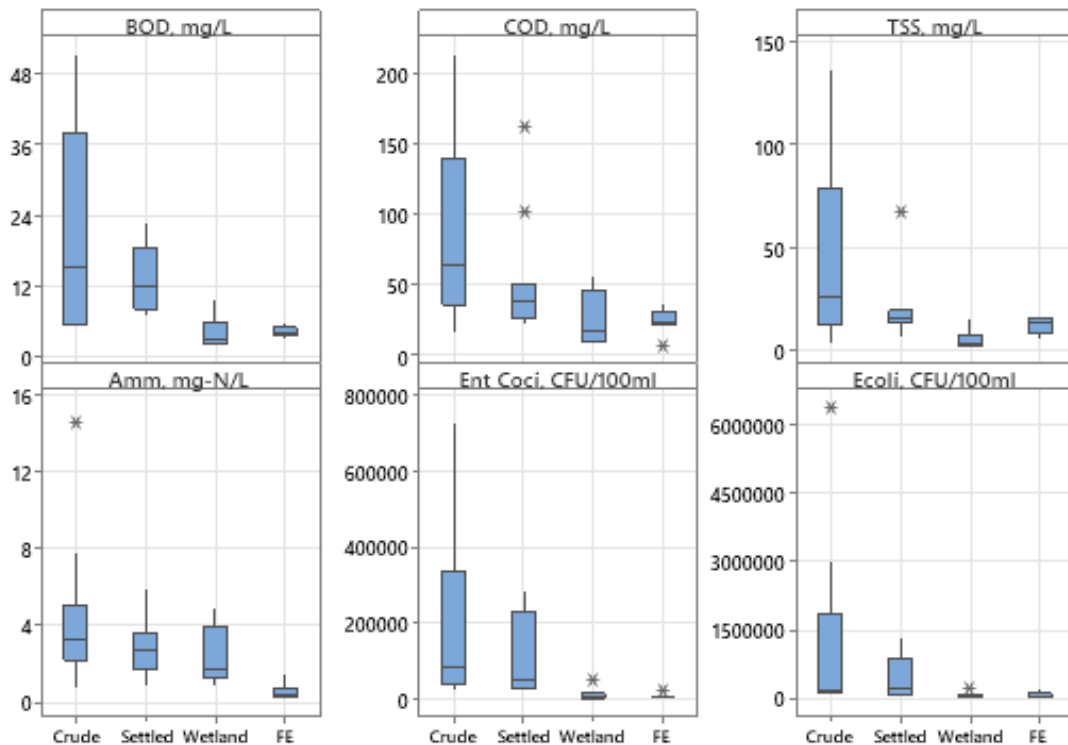
#### Site A2: Lavant. Southern Water

The Lavant WWTW scheme, 2600 pe, is considered more detail as Southern Water have made monitoring data available. This site is in a chalk catchment and has groundwater ingress when levels are high. In this scheme an aerated TW has been added downstream of a storm tank that has been converted into a sedimentation tank, the schematic process flow is shown in Fig B1. This increases the treatment capacity from 34 L/s FFT to 70 L/s. Lavant WWTW has discharge permits standards of 40 mg/L TSS, 20 mg/L BOD and 20 mg-N/L NH<sub>4</sub>-N.



**Figure B1.** Schematic process flow at Lavant WTW

The boxplots of water quality through the plant are shown in Fig B2, with the horizontal line showing the median, the boxes the inter quartile ranges and stars showing outliers. The effect of the groundwater and stormwaters can be seen in the low crude mean values of 46 mg/L BOD and 11 mg/L TSS, although spikes of NH<sub>4</sub>-N are seen (max. 51) giving a mean of 22 mg-N/L.



**Figure B2.** Box Plots of water quality through Lavant WTW

There are good removals of a range of parameters across the plant. These are considered in more detail in Table B1 which considers both the mean and median values as the sample (n 8 to 10) was a bit small to undertake normality tests. The values are considered for the storm overflow pathway from the crude, through the settling tank, then onto the TW before mixing with the main treatment stream from the trickling filters. Table B1 also considers the cumulative % removals of each pollutant through the plant and also the specific % removal seen across the TW.

The mean final effluent COD was 24.4 mg/L compared to the UWWD limit of 125 mg/l. The influent was very dilute at 85.8 mg/L, so despite a very clean effluent the overall % removal was 72%. A similar pattern was seen for BOD with median wetland effluent concentrations of less than 4 mg/l with a similar picture for TSS at 3.9 mg/L with slightly higher levels in the final effluent (FE) blended with the TF effluents. For indicator organisms (E coli and Ent Cocci) these are constantly 1-2 log order reductions with at least 1 log reduction across the TW.  $\text{NH}_4\text{-N}$  removals were also slightly lower but spikes in the influent were effectively buffers and the effluent at about 4 mg/l was well within consent. Overall removals of TN in the WWTW were seen but removals of TP were less which is consistent with the expectations of this type of wetland. TN removal; across wetland is minimal, but this is to be expected at the low C:N in the sewage and the wetlands will be predominantly aerobic and unsuitable for high rates of heterotrophic denitrification, also the levels of TN are also low. The % removals across the wetland are included to assess their performance at these low concentrations. As many treatment mechanisms have underlying first order reaction rates it is common to see much higher removal rates for stronger sewage, particularly over the first unit processes in a WWTW.

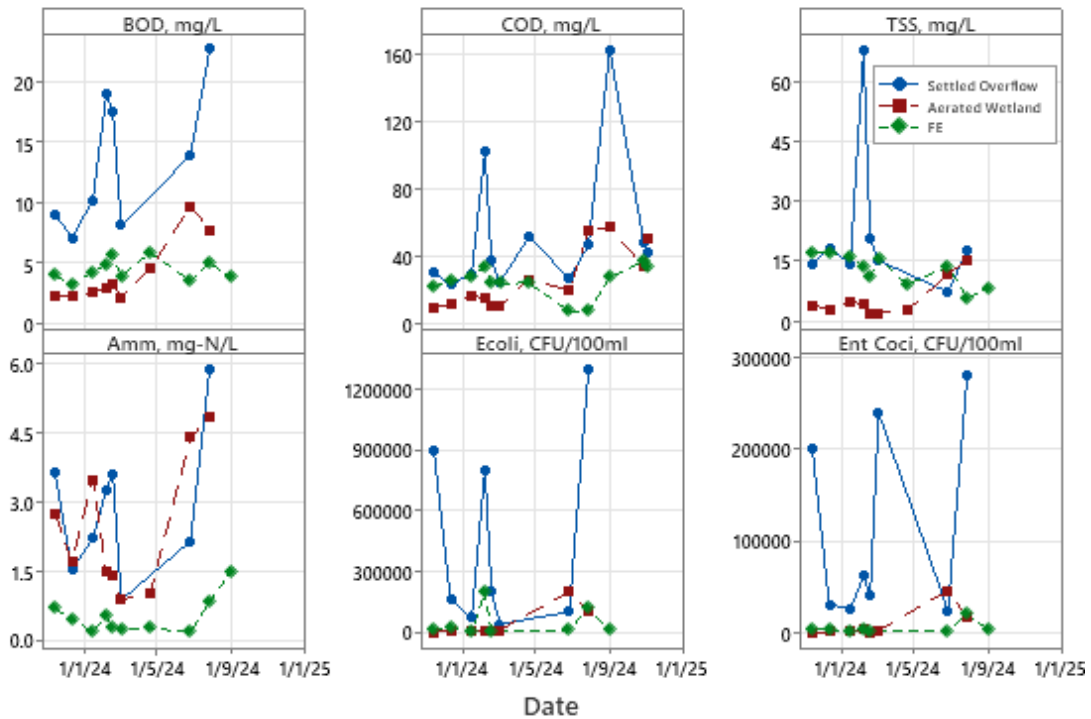
**Table B1:** Data Summary through Lavant WTW Showing Cumulative % removals (n=8-10)

	Location	Mean	SD	Σ Mean % Removal	Median	IQR	Σ Median % Removal
<b>COD, mg/L</b>	Crude	85.8	65.2		64.1	104.3	
	Settled Overflow	51.9	40.9	40	39.5	23.2	39
	Aerated Wetland	26.3	18.4	69 (49*)	18.2	35.7	72 (54*)
	FE	24.4	9.4	72	25.6	9.8	62
<b>BOD, mg/L</b>	Crude	22.0	17.3		15.4	32.5	
	Settled Overflow	13.4	5.7	53	12.1	10.2	21
	Aerated Wetland	4.2	2.7	88 (75*)	3.0	3.9	80 (75*)
	FE	4.4	0.9	72	4.1	1.4	73
<b>Ent Cocci, CFU/100ml</b>	Crude	188778	268059		80000	300000	
	Settled Overflow	112750	108170	40	51000	203500	36
	Aerated Wetland	8811	15894	95 (92*)	1800	12005	98 (96*)
	FE	4713	6227	98	3100	1750	96
<b>E. coli, CFU/100ml</b>	Crude	1236667	2150727		140000	1750000.0	
	Settled Overflow	446250	482403	64	180000	797500	-29
	Aerated Wetland	41913	71917	94 (91*)	6500	72750	95 (96*)
	FE	47000	73155	96	10000	89500	93
<b>NH4-N mg-N/L</b>	Crude	4.4	4.0		3.3	2.8	
	Settled Overflow	2.9	1.6	35	2.7	1.9	17

	Location	Mean	SD	Σ Mean % Removal	Median	IQR	Σ Median % Removal
	Aerated Wetland	2.4	1.5	66 (15*)	1.7	2.7	48 (38)
	FE	0.5	0.4	88	0.4	0.5	89
<b>TSS, mg/L</b>	Crude	46.0	48.2		26.2	66.4	
	Settled Overflow	21.8	19.0	53	16.4	5.8	37
	Aerated Wetland	5.5	4.7	90 (75*)	3.9	5.8	78 (76*)
	FE	12.7	4.0	72	13.6	7.5	48
<b>TN mg-N/L</b>	Crude	11.2	7.4		8.8	2.9	
	Settled Overflow	9.4	3.5	16	8.7	2.9	2
	Aerated Wetland	5.7	0.8	93 (39*)	5.7	1.2	87 (34*)
	FE	8.0	0.9	28	7.9	1.7	10
<b>TP mg-P/L</b>	Crude	1.1	0.7		0.9	0.6	
	Settled Overflow	0.7	0.3	31	0.7	0.5	22
	Aerated Wetland	0.6	0.3	45 (20*)	0.5	0.3	46 (31*)
	FE	0.8	0.2	20	0.8	0.2	14

(\*)\* values are % removals only across the TW

**Figure B3.** focuses on the wetland influent, effluent and the combined FE with a time series plot. The plot show that the wetland was able to reduce spikes in the influent for BOD, TSS and NH<sub>4</sub>-N, with TW effluent values below the combined FE. The indicator organisms also show the wetland reducing numbers but in particular the high spikes seen in the influent are effectively balanced and smoothed.

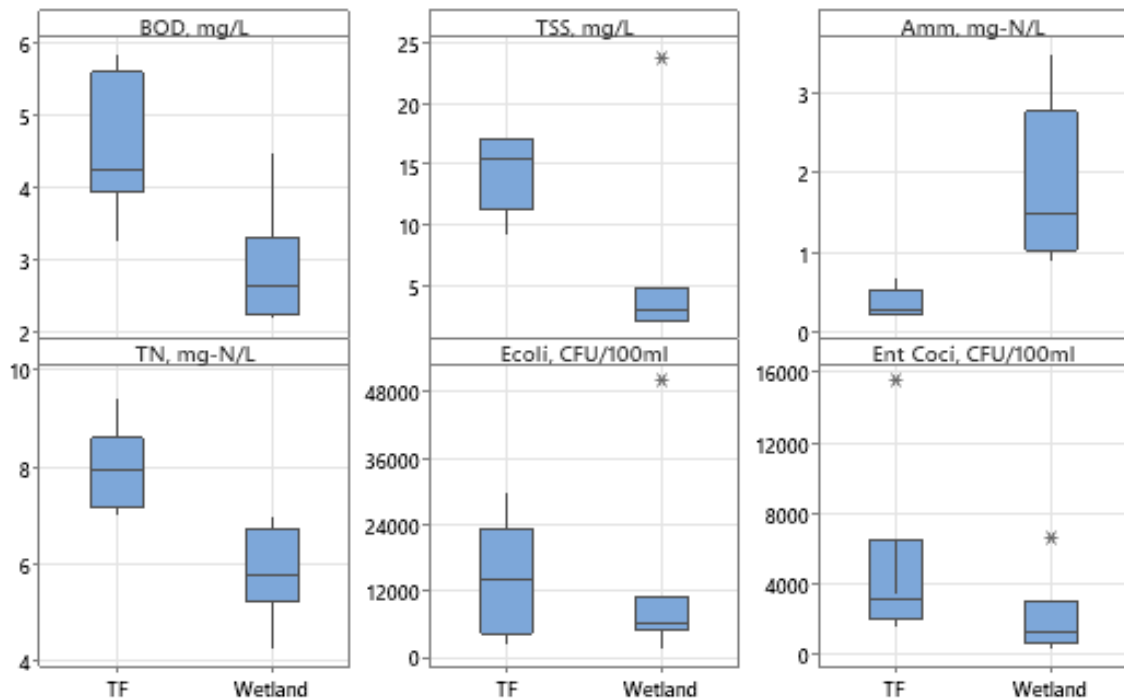


**Figure B3.** Time series plots of water quality through the settling tank/aerated wetland system.

Additional sampling was also undertaken at the influent, effluent and mid-point in 7/24. These spot samples have similar low effluent values but apart from TSS removals are generally lower than the combined data set.

**Table B2.** Southern Water Sampling additional sampling, 16/7/24

Location	NH <sub>4</sub> -N, mg/L	BOD, mg/L	COD, mg/L	NO <sub>3</sub> -N, mg-N/L	NO <sub>2</sub> -N, mg-N/L	TP, mg-P/L	SS, mg/L	TN, mg-N/L
Wetland In	5.53	17.90	55.0	0.90	0.405	1.320	30.2	6.81
Mid-point	5.60	24.40	57.3	0.95	0.454	1.270	44.8	7.06
Wetland Outlet	4.96	6.48	33.5	0.75	0.458	0.918	4.4	6.56

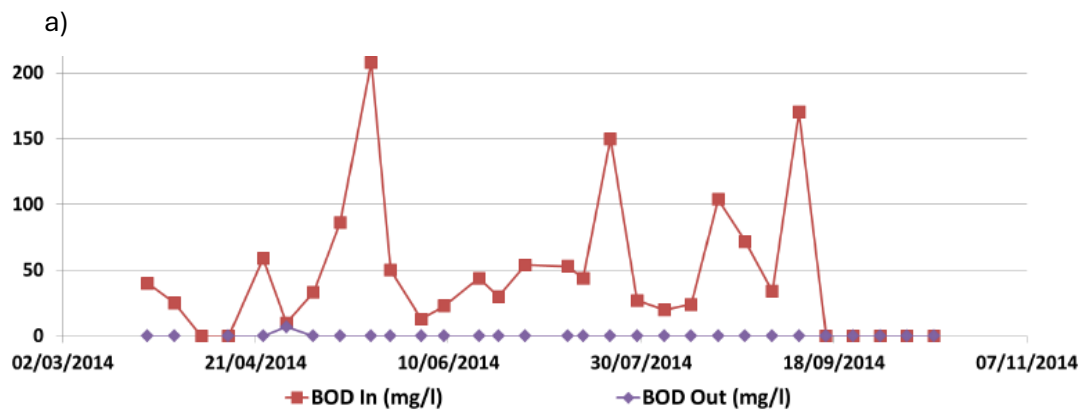


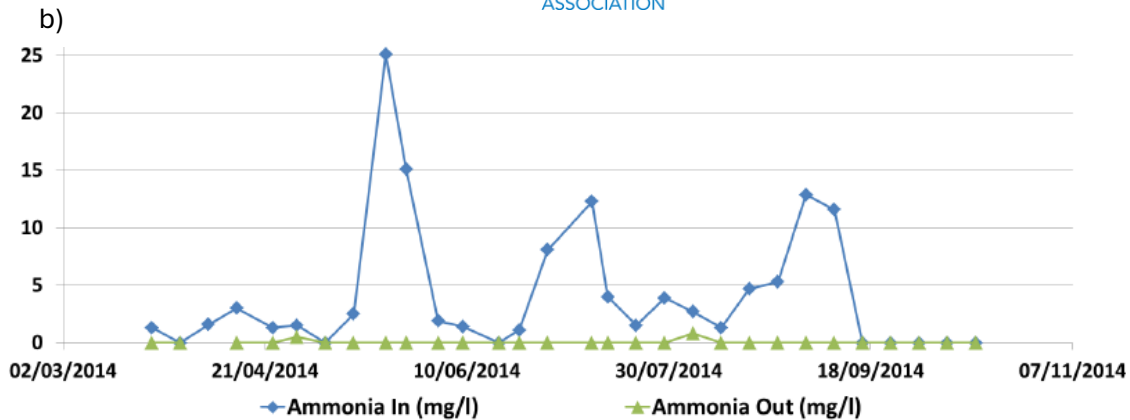
**Figure B4.** Box Plots comparison of water quality from the TW and trickling filters at Lavant WTW

## B. Wetlands in the network

### Site B1: Aerated wetland, Scottish Water.

The Cowdenbeath TW was commissioned by Scottish Water to treat increased CSOs from urban expansion. A vertical flow forced bed aeration wetland was installed by ARM Ltd (ARMStorm™) with flows fed to the bed at a maximum rate of 46 L/s from a 3000 m<sup>3</sup> holding tank. The bed is deeper than usual at 2 m to save space with an area of 4,000 m<sup>2</sup> and a 4000 m<sup>3</sup>/d treatment capacity. It operates at a consent of 9.0 mg/L BOD and 1.5 mg N/L NH<sub>4</sub>-N (ARM, undated). Early performance data was shared by Scottish Water at a conference in 2015 (Figure B5; Otero and Ergan 2015).

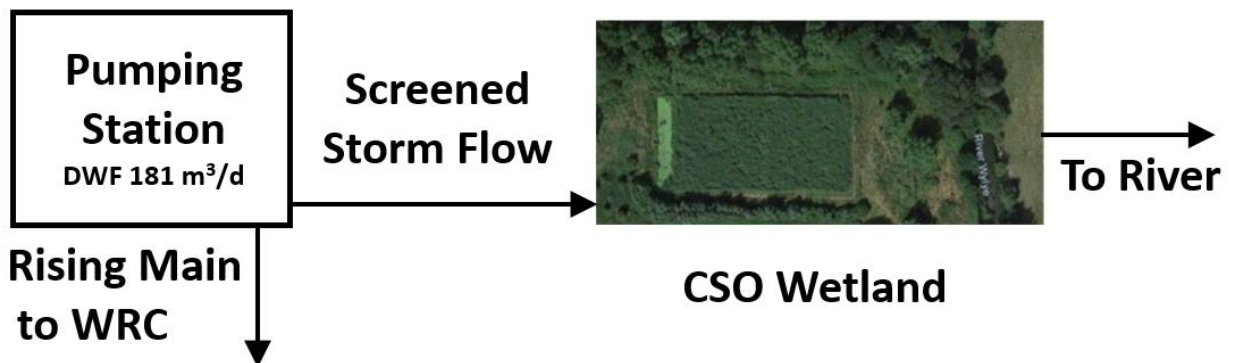




**Figure B5.** Commissioning data for storm overflow system in Scottish Water. (a) BOD, and (b) ammonia. Otero and Ergon (2015).

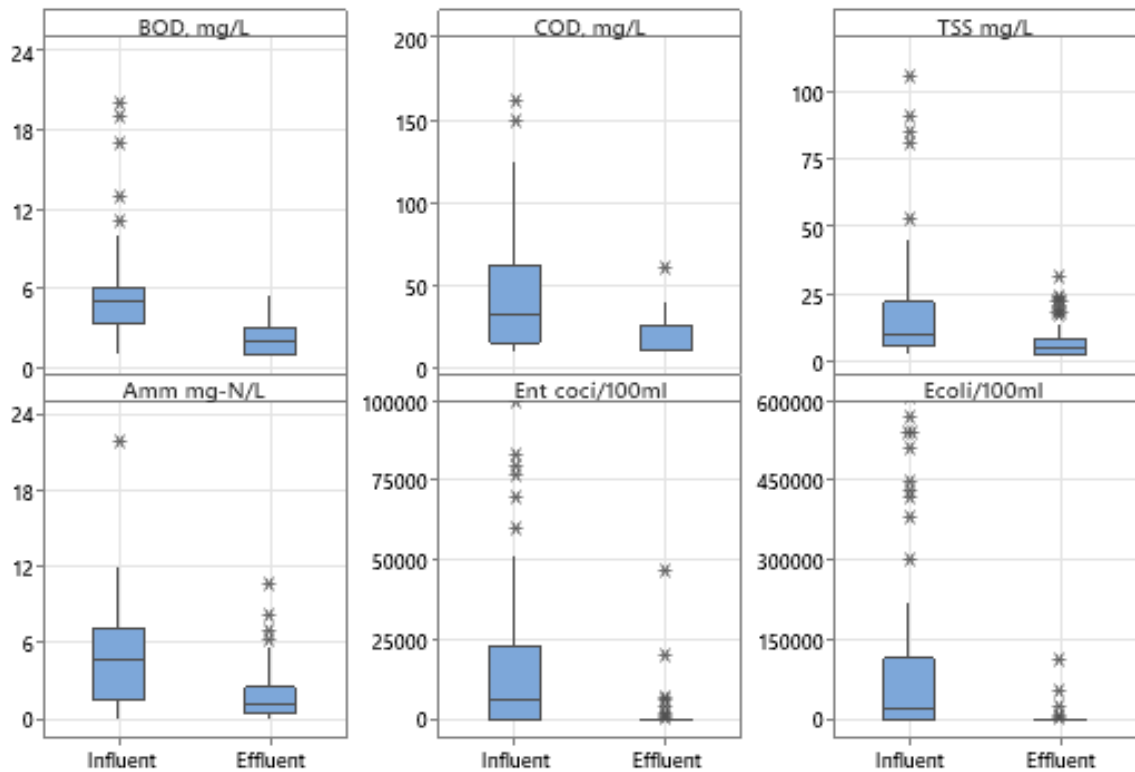
*Site B2: Horizontal flow wetland, Wessex Water.*

Hanging Langford Pumping Station has a 2625 m<sup>2</sup> horizontal flow wetland for an initial 3-year trial from 1/2024 in agreement with the Environment Agency (**Figure B6**). It is close to Shrewton and has similar issues with groundwater infiltration. Wessex had already taken measures to reduce river ingress that reduced spills from 360 to 109 between 2019 and 2023.



**Figure B6.** Schematic process flow at Hanging Langford Pumping Station

The water quality improvements across the wetland are shown in **Figure B7** and **Table B2**. BOD and COD in the influent are relatively low at with medians of 32 and 5 mg/L respectively. These low levels were often below the Limit of Detection (LOD) so the % removals of about 70 and 60% are not very representative. There is evidence of ammoniacal N removals of 73% with a median effluent of 1.3 mg-N/L suggesting nitrification in the wetland. Very good removals of the indicator bacteria were seen with 99% (2 log order) reductions of both E. coli and Enterococci. The CSO wetland is therefore producing a very good effluent with concentrations of some parameters below that normally expected from a small WWtW.



**Figure B7.** Box Plots of water quality through Hanging Langford CSO wetland and river

Table B2 also summarises the data recorded upstream and downstream of the outfall, these are also compared in the box plots in Figure B8.

**Table B2.** Data Summary through Hanging Langford Showing Cumulative % removals (n=)

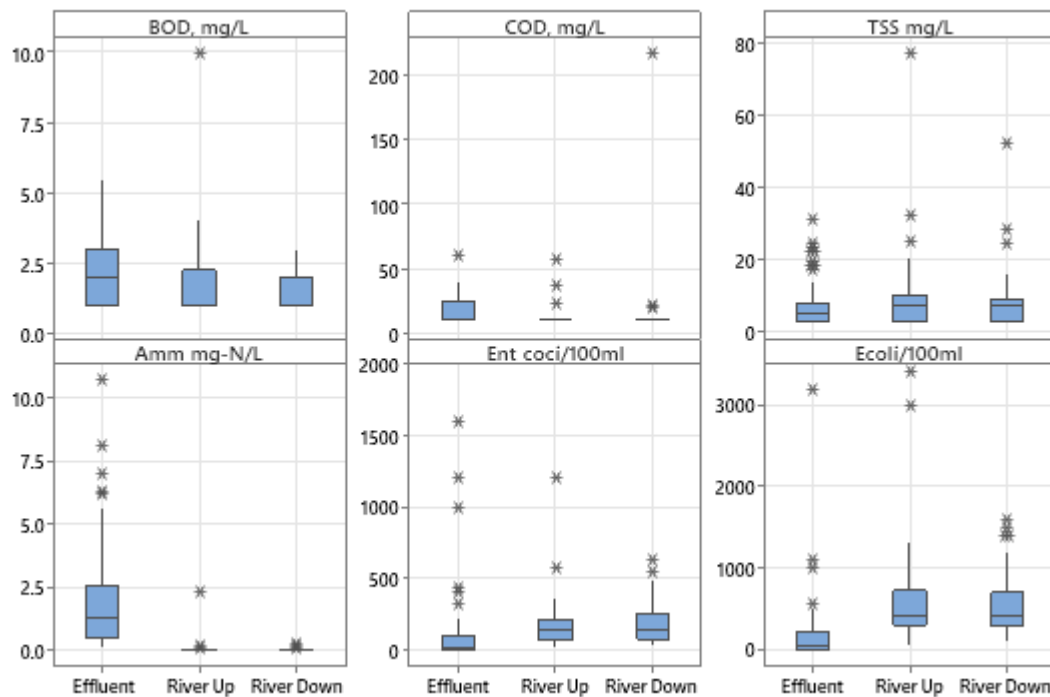
Parameter	Location	n	Mean	SD	Mean % Removal	Median	Median % Removal
COD, mg/L	Influent	33	54.1	67.5		32.0	
	Effluent	32	18.0	12.6	66	10.0	69
	River Up	27	13.2	10.4		10.0	
	River Down	27	18.4	39.8		10.0	
BOD, mg/L	Influent	64	7.0	11.3		5.0	
	Effluent	62	2.2	1.1	68	2.0	60
	River Up	30	1.9	1.8		1.0	
	River Down	30	1.4	0.7		1.0	

Parameter	Location	n	Mean	SD	Mean % Removal	Median	Median % Removal
<b>Ent Cocci, CFU/100ml</b>	Influent	76	27314.1	56865.0		6150.0	
	Effluent	55	1644.5	6896.7	94	20.0	99
	River Up	43	2840.5	12710.0		140.0	
	River Down	43	186.7	146.0		140.0	
<b>E. coli, CFU/100ml</b>	Influent	76	121628.0	235310.0		19400.0	
	Effluent	72	3563.3	14765.6	97	45.0	99
	River Up	43	14768.8	76844.5		420.0	
	River Down	43	707.2	873.6		430.0	
<b>NH<sub>4</sub>-N mg-N/L</b>	Influent	75	8.3	13.8		4.7	
	Effluent	70	2.0	2.2	76	1.3	73
	River Up	42	0.1	0.3		0.0	
	River Down	42	0.0	0.0		0.0	
<b>TSS, mg/L</b>	Influent	75	21.2	36.7		10.0	
	Effluent	70	7.2	6.3	65	5.0	50
	River Up	42	9.6	12.5		7.0	
	River Down	42	8.6	8.9		7.0	
<b>TON mg-N/L</b>	Influent	42	1.4	1.9		0.2	
	Effluent	37	0.4	0.6	69	0.1	50
	River Up	29	6.0	0.8		6.1	
	River Down	29	6.1	0.5		6.1	
<b>SRP mg-P/L</b>	Influent	59	1.7	2.3		1.1	
	Effluent	53	1.0	0.7	40	1.0	7

Parameter	Location	n	Mean	SD	Mean % Removal	Median	Median % Removal
	River Up	42	0.1	0.1		0.1	
	River Down	42	0.1	0.0		0.1	

LODs included as LOD/2 \*all values below LOD.

**Figure B8** show that BOD from the CSO wetland was similar to the river, with many values of both sample below the LOD. The boxplots show a slightly higher COD range, but the median bar is at 10 mg/l the same as the river upstream and downstream. This is due to an outlier of 60 mg/L in November 2022 and a few values around 40 mg/l at other times which are still very low and below the UWWTD value of 125 mg/l.



**Figure B8.** Box Plots comparing the CSO effluent with river upstream and downstream of the outfall (Note: 2 To allow data to be seen more clearly 2 outliers from Effluent and River up not shown for Ent Cocci and 1 outlier from effluent and two from River up not shown for E. coli).

Indicator bacteria in the effluent from the wetland were generally lower than that in the river upstream and downstream of the discharge. There is the wide variation that is usually encountered in microbial counts, but it is reassuring that the wetland is potentially reducing the pathogen load in the river. This is an agricultural area so further investigations would be required to assess the sources of the bacterial load in the river.

### C. Historic data from Severn Trent wetlands (“reedbeds”)

The paper cited in the body of the report (Griffin 2004) summarised Severn Trent’s 10 years of experience with wetland applications. As part of that report, there was a detailed assessment of a dedicated storm overflow wetland (Lighthorne Heath) and a combined storm and tertiary treatment wetland (Stretton on Fosse). Results included a detailed profile of inlet and outlet concentrations (**Table C1**) and a summary of performance for the combined wetland/stepped flow wetland for eight years (Table C2).

**Table C1.** Detailed results of storm event surveys at storm overflow only and combined wetlands (Griffin 2004).

	Date of storm survey				
	Lighthorne Heath			Stretton on Fosse	
	11–13th June 93	13–15th Nov 93	5–6th Jan 94	07th Feb 96	08th Feb 96
Storm duration (hr)	32	36	27	24	52
Peak flow rate ( $l\ s^{-1}$ )	11.1	9.7	11.1	7.8	
Cumulative vol. treated ( $m^3$ )	237	417	301	371	601
Hydraulic load ( $cm\ d^{-1}$ )	25	40	38	98	73
Mean influent BOD ( $mg\ l^{-1}$ )	35	45	51	21	20
Peak influent BOD ( $mg\ l^{-1}$ )	86	363	147	37	37
Mean effluent BOD ( $mg\ l^{-1}$ )	8.4	10.3	10.3	6.0	1.9
Peak effluent BOD ( $mg\ l^{-1}$ )	11.6	18	13.2	12	5.7
Mean influent TSS ( $mg\ l^{-1}$ )	85	109	127	39	27
Peak influent TSS ( $mg\ l^{-1}$ )	266	1,070	292	80	80
Mean effluent TSS ( $mg\ l^{-1}$ )	15.6	17.3	25.9	7.8	5.3
Peak effluent TSS ( $mg\ l^{-1}$ )	25	48	36	22	22
Mean influent $NH_4-N$ ( $mg\ l^{-1}$ )	4.1	4.2	5.8	2.27	1.5
Peak influent $NH_4-N$ ( $mg\ l^{-1}$ )	20.4	40.4	12.4	6.7	6.7
Mean effluent $NH_4-N$ ( $mg\ l^{-1}$ )	2.4	1.8	2.9	1.8	1.2
Peak effluent $NH_4-N$ ( $mg\ l^{-1}$ )	3.0	2.3	3.7	4.1	4.1
Mean influent TON ( $mg\ l^{-1}$ )	6.6	5.1	4.7	13.4	13.8
Peak influent TON ( $mg\ l^{-1}$ )	9.8	6.5	6.4	18.9	18.9
Mean effluent TON ( $mg\ l^{-1}$ )	1.5	1.3	1.4	13.8	13.3
Peak effluent TON ( $mg\ l^{-1}$ )	3.8	3.2	3.1	16	16

**Table C2** Annual average and 95% percentiles for combined storm overflow and tertiary treatment bed at Stretton on Fosse during 1994-2002. Concentrations in mg/L (Griffin 2004).

Year	Mean $BOD_5$	$BOD_5$ 95%ile	Mean TSS	TSS 95%ile	Number of samples
1994	4	11.7	6.9	16.9	12
1995	1.5	3.2	2.2	4.9	12
1996	1.1	2.0	2	3.5	12
1997	1.3	3.2	2	3.5	12
1998	1	1.8	1.9	3.5	12
1999	3.8	14.5	5.9	10.5	11
2000	1.9	3.4	5.2	9.5	11
2001	3.8	9.8	6.1	14.1	7
2002 to August	3.8	10.6	5.3	16.8	8

## References

- ARM Undated. Water company case studies. Accessed in January 2025: <https://armreedbeds.co.uk/wp-content/uploads/2017/02/Water-Company.pdf>. Case studies in pages 16 and 20.
- Baggaley, L and Griffin, P. 2005. A review of the construction and performance of secondary treatment reed beds. Report RD 8160, Severn Trent, Coventry, UK.
- Betts, J. 2023. Opportunities for storm water treatment – design, construction and operational experiences of United Utilities’s first storm water wetland at Southwaite WwTWs. Presentation at EWWM Conference. 4 – 5<sup>th</sup> July 2023, Manchester, UK.
- Boon, A. 1985. Report of a visit by members and staff of WRc to Germany (GFR) to investigate the root zone method for the treatment of waste waters. Report 376-S/1. WRc, Swindon, UK.
- Butterworth, E. Richards, A., Jones, M., Mansi, G., Ranieri, E., Dotro, G., Jefferson, B. 2016. Performance of four full-scale artificially aerated horizontal flow constructed wetlands for domestic wastewater treatment. *Water* 8(9): 365. <https://doi.org/10.3390/w8090365>
- Cooper, P.F. 1990. European Design and Operation Guidelines for Reed Bed Treatment Systems. WRc report UI 117, Swindon, U.K.
- CWA 2024. Constructed Wetland Association website. <https://constructedwetland.co.uk/>
- Defra 2025. Water quality archives. Accessed in January and March 2025: [Open WIMS data](#).
- DEHLG 2010. Integrated Constructed Wetlands: Guidance Document for Farmyard Soiled Water and Domestic Wastewater Applications. Republic of Ireland Department of the Environment, Heritage and Local Government.  
<https://www.watersoflife.ie/app/uploads/2023/07/Wetland-Guidance.pdf>
- Dotro, D., Langergraber, G., Molle, P., Nivala, J., Puigagut, J. Stein, O., von Sperling, M. 2017. *Treatment Wetlands, Biological Wastewater Treatment 7*. IWA Publishing, UK.
- Engstler E., Kerschbaumer, D.J. Langergraber G. 2022. Evaluating the Performance of Small Wastewater Treatment Plants. *Frontiers in Environmental Science*. 10. <https://doi.org/10.3389/fenvs.2022.948366>
- Ferrera, I., Sánchez, O. 2016. Insights into microbial diversity in wastewater treatment systems: How far have we come? *Biotechnology Advances*. 34: 5. 790-802. <https://doi.org/10.1016/j.biotechadv.2016.04.003>.
- Fonseca, N. 2018. Reactive media for phosphorus removal in wastewater treatment. PhD thesis, Cranfield University. Accessed January 2025:  
<https://dspace.lib.cranfield.ac.uk/server/api/core/bitstreams/ea85d9c-b3cd-48c2-97d1-39c5afb11997/content>
- Griffin, P. 2004. Ten years’ experience of treating all flows from combined sewerage systems using package plant and constructed wetland combinations. *Water Sci Technol*. 48 (11-12): 93–99. <https://doi.org/10.2166/wst.2004.0813>
- Kadlec, R. and Wallace, S. (2009). *Treatment wetlands*. Second edition. CRC Press, USA.

Khomenko, O. 2019. Adaptation of two-stage vertical flow constructed wetlands for treating unscreened sewage in the UK. MSc Thesis, Cranfield University. <https://dspace.lib.cranfield.ac.uk/items/8ba4220a-ad49-40ea-b9ec-edd57b1f1100>

Masi, F. Bresciani, R., Martinuzzi, N., Cigarini, G., Rizzo, A. 2017. Large scale application of French reed beds: municipal wastewater treatment for a 20,000 inhabitants' town in Moldova. *Water Science and Technology*, 76(1). <https://doi.org/10.2166/wst.2017.188>

Murujew, O. 2019. Tertiary phosphorus removal. PhD Thesis, Cranfield University. [https://dspace.lib.cranfield.ac.uk/bitstream/handle/1826/20839/Murujew\\_O\\_2019.pdf](https://dspace.lib.cranfield.ac.uk/bitstream/handle/1826/20839/Murujew_O_2019.pdf)

Otero, R, and Ergon, J. 2015. A review of constructed wetlands in Scottish Water. Presented at *4<sup>th</sup> Low Energy Wastewater Treatment Systems Conference, Cranfield University, UK.*

Pereira Gómez, L. 2016. Vertical flow constructed wetlands for treating unscreened sewage in the UK. MSc Thesis, Cranfield University. Accessed January 2025:

<https://dspace.lib.cranfield.ac.uk/server/api/core/bitstreams/f3d1215a-723e-49d2-be81-4a0e21c1e5f9/content>

Ruppelt, J.P., Tondera, K., Wallace, S.J., Button, M., Pinnekamp, J., Weber, K.P. 2020. Assessing the role of microbial communities in the performance of constructed wetlands used to treat combined sewer overflows, *Science of The Total Environment*, 736,139519/ <https://doi.org/10.1016/j.scitotenv.2020.139519>

Stefanakis A.I., Bardiau M., Trajano D., Couceiro F., Williams J.B., Taylor H. 2019. Presence of bacteria and bacteriophages in full-scale trickling filters and an aerated constructed wetland. *Science of the Total Environment*. 659: 1135-1145. <https://doi.org/10.1016/j.scitotenv.2018.12.415>

Vymazal, J. 2011. Constructed wetlands for wastewater treatment: five decades of experience. *Environmental Science and Technology*. 45(1). <https://doi.org/10.1021/es101403q>

Weedon et al 2017. Establishing a design for passive vertical flow constructed wetlands treating small sewage discharges to meet British Standard EN 12566. <https://doi.org/10.1080/09593330.2016.1191549>



## About the authors

Gabriela Dotro is a Visiting Fellow at Cranfield University, after working there for 15 years in close partnership with UK water utilities and the Environment Agency on technologies for wastewater treatment (nature-based solutions as well as grey technologies). She led the NbS work at Cranfield and has served as elected Chair of the Constructed Wetland Association (CWA) since 2023. She has served as an elected committee member of the CWA since 2010 and as elected member of the Management Committee of the International Water Association (IWA) Specialist Group on Wetland Systems for Water Pollution control since 2012. She led the creation and delivery of the IWA's Task Group on Mainstreaming Treatment Wetlands in 2014-2018, which produced two open access reference books on the technology and its application worldwide. She has worked with wetland technology in Canada, the USA, Argentina and the UK, spanning storm water treatment, industrial wastewater treatment and sewage treatment applications. She helped adapt and implement aerated wetlands and the first French style wetland at Severn Trent among other key projects including supporting the implementation of a new wetland-based flowsheet in Scotland. She is an independent consultant at NbS Future, a specialist consulting firm dedicated to supporting the implementation of nature-based solutions for wastewater treatment based on robust evidence.

John Williams is Professor of Environmental Technology in the School of Civil Engineering and Surveying at the University of Portsmouth. His PhD (1988-93) examined the use of constructed wetlands for wastewater treatment in the UK and Egypt, with particular focus on nitrogen cycling and pathogen removal. He has worked on many research projects examining wastewater treatment and has maintained his active interest in constructed wetlands, working in Colombia and Greece. John has also studied the use of vegetated systems for Sustainable Drainage of runoff from highways and housing developments, with a recent collaboration in Thailand examining wetlands for pesticide removal from irrigation waters contaminated with agricultural runoff.